

Z-Wave MultiSensor

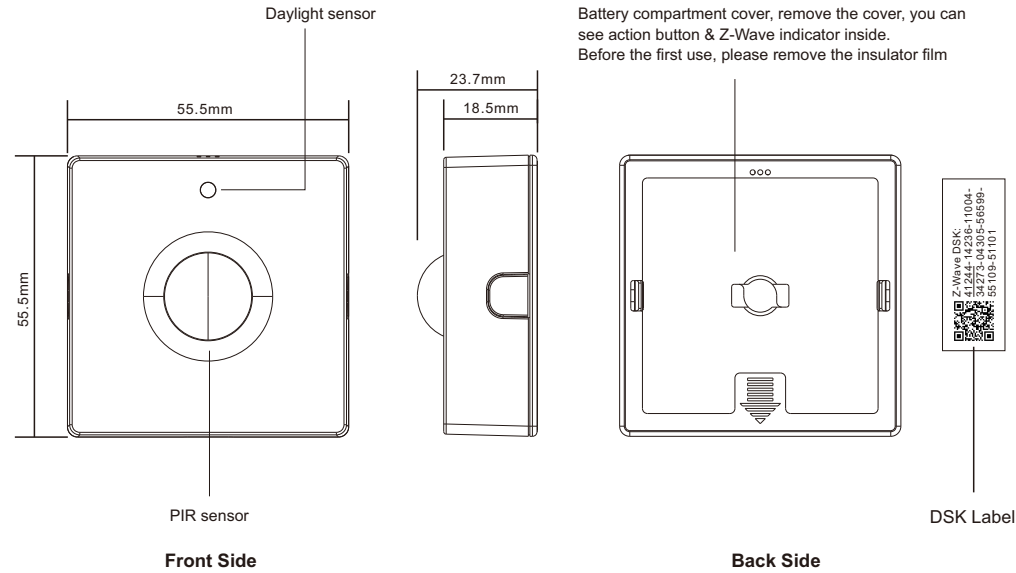

Important: Read All Instructions Prior to Installation

Function introduction



Product Data

| | |
|---------------------------------|-----------------------------------|
| Radio Frequency | 868.42 MHz (EU) |
| Power Supply | 3VDC (2*AAA Batteries) |
| Temperature Range and Precision | -40°C~+125°C, ±0.3°C |
| Humidity Range and Precision | 0 – 100% RH (non-condensing), ±3% |
| Dimensions | 55.5×55.5×23.7(mm) |
| Recommended Installation Height | 2.4 meters |
| PIR sensor Detection Range | Max. 7 meters |
| Illuminance Measuring Range | 0~32767 lux |

Detection Range

Detection range of the Motion Sensor is shown below. Actual range of the Sensor can be influenced by environmental conditions.

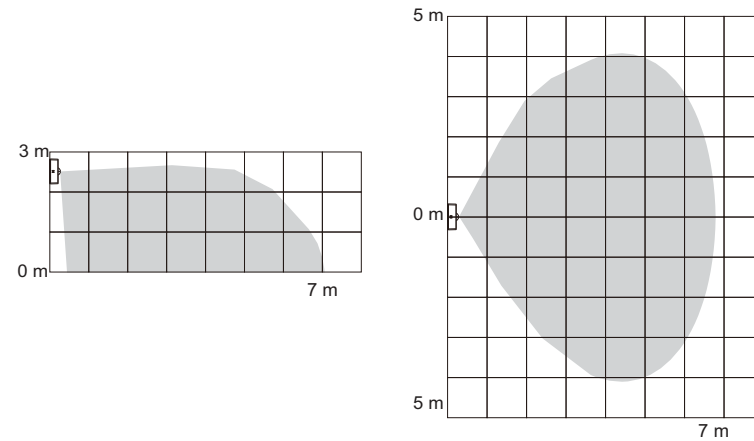

Inclusion (adding to a Z-Wave network)

1. Set primary controller/gateway into inclusion mode (Please refer to your primary controllers manual on how to turn your controller into inclusion).
2. Make sure the sensor does not belong to any Z-Wave network. If the sensor has already been included into a network, it shall be removed from the network first. There are two methods to set the sensor into inclusion mode:
 - 1) Triple press the action button on the sensor, it will set the sensor into inclusion mode.
 - 2) Make sure that the sensor does not belong to any Z-Wave network, remove battery of the sensor and re-install again to reset power of the sensor, it will be set into inclusion mode automatically, and waiting to be included.

The LED indicator will flash fast to indicate successful inclusion.

Note: During inclusion process, triple press the action button 3 times again will enable the sensor to exit inclusion mode.

SMART START

If the user's gateway also supports smartstart, add the device by scanning the QR code, Smartstart allows users to quickly add devices to the gateway by scanning the device's QR code.
After scanning to add the device, remove the batteries of the device and install them again or waiting for a while, the device will be added to the gateway automatically. Please find the QR code on the battery compartment cover of the device.

Exclusion (removing from a Z-Wave network)

There are two exclusion methods:

Method 1: Exclusion from the primary controller/gateway as follows:

1. Set the primary controller/gateway into exclusion mode (Please refer to your primary controllers manual on how to set your controller into exclusion).
2. Triple press the action button, the sensor will be set to exclusion mode, the LED indicator will flash fast and then the sensor will be removed from the network and reset to factory defaults.

Note: During exclusion process, triple press the action button 3 times again will enable the sensor to exit exclusion mode.

Method 2: Factory reset the sensor will force it to be excluded from a network. (please refer to the part "Factory Reset" of this manual)

Note: Factory reset is not recommended for exclusion, please use this procedure only if the primary controller/gateway is missing or otherwise inoperable.

Factory Reset

Press and hold down action button for over 10 seconds, then LED indicator will flash 3 times slowly to indicate successful factory reset, the sensor will be removed from the network and reset to factory defaults.

Wake Up

Press and hold action button for 1 second to send Wakeup Notification CC to lifeline.

Trigger Notification (Motion Detection) and Basic Set

- 1) PIR on/off and sensitivity configuration (configuration parameter 3)
- 2) When PIR is triggered, send Notification to Group 1, and send Basic Set to associated devices of Group 2.
- 3) If PIR is triggered, and within 30 seconds, not triggered again (the time can be configured via configuration parameter 7), send Notification to Group 1, and send Basic Set (0x00) to associated devices of Group 2.

Brightness Report

- 1) Once the sensor is added to a Z-Wave network, it will report the brightness after 10 seconds.
- 2) Report the brightness periodically (the time can be configured via configuration parameter 13).
- 3) When brightness exceeds the setting threshold (can be configured via configuration parameter 14), the sensor will report corresponding brightness.

Temperature Report

The unit of the reported temperature and displayed on the LCD screen is degree celsius.

- 1) Once the sensor is added to a Z-Wave network, it will report the temperature after 10 seconds.
- 2) Report the temperature periodically (the time can be configured via configuration parameter 3).
- 3) When temperature exceeds the setting threshold (can be configured via configuration parameter 4), the sensor will report corresponding temperature.

Note: temperature accuracy is one decimal place.

Humidity Report

- 1) Once the sensor is added to a Z-Wave network, it will report the humidity after 10 seconds.
- 2) Report the humidity periodically (the time can be configured via configuration parameter 5).
- 3) When humidity exceeds the setting threshold (can be configured via configuration parameter 6), the sensor will report corresponding humidity.

Association

Z-Wave devices control other Z-Wave devices. The relationship between one device controlling another device is called association. In order to control a different device, the controlling device needs to maintain a list of devices that will receive controlling commands. These lists are called association groups and they are always related to certain events (e.g. button pressed). In case the event happens all devices stored in the respective association group will receive a common wireless command.

Association Groups:

| Association Groups | Group Name | Max Nodes | Description |
|--------------------|------------|-----------|---|
| Group 1 | Lifeline | 5 | <ol style="list-style-type: none">1. When factory reset the sensor, send "Device Reset Locally Notification CC" to associated devices of this group to report factory reset information.2. When motion detected, send "Notification Report" to associated devices of this group.3. Send "Sensor Multilevel Report" to associated devices of this group.4. Send "Battery Report" to associated devices of this group. |
| Group 2 | Motion | 5 | When motion detected, send "Basic Set 0xFF/0x00" to associated devices of this group. |

Set and unset associations:

(Note: All association information will be cleared automatically once the sensor is excluded from a network.)

Set association by operating primary controller/gateway to send packets to the sensor:

The primary controller/gateway sends packets to the sensor using "Command Class ASSOCIATION"

Node Information Frame

The Node Information Frame is the business card of a Z-Wave device. It contains information about the device type and the technical capabilities. The inclusion and exclusion of the device is confirmed by sending out a Node Information Frame. Beside this it may be needed for certain network operations to send out a Node Information Frame.

How to send out Node Information Frame:

When the sensor is set to inclusion/exclusion mode again, it will send out Node Information Frame, there are 2 kinds of operation as follows:

1. Triple press the action button, the sensor will be set to inclusion/exclusion mode, then send out Node Information Frame.

2. When the sensor is under inclusion mode, there are two kinds of operation:

1) Triple press action button, the sensor will be set to inclusion mode again, and send out Node Information Frame.

2) If the sensor does not belong to any Z-Wave network, remove the batteries and reinstall them to repower on the sensor, it will be set to inclusion mode automatically, and send out Node Information Frame.

Technical Data

| | |
|-------------------------|---|
| Wireless Range | Up to 100 m outside, on average up to 40 m inside buildings |
| SDK | 7.13.6 |
| Explorer Frame Support | Yes |
| Device Type | Notification Sensor |
| Generic Device Class | Sensor Notification |
| Specific Device Class | Notification Sensor |
| Role Type | Reporting Sleeping Slave (RSS) |
| Supporting Device Type | Actuator |
| Requested security keys | S0, S2_UNAUTHENTICATED and S2_AUTHENTICATED |

Notification

The sensor supports Home Security (0x07), when motion event triggered, send Motion Detection (0x08) to associated devices of group 1.

When motion event cleared, send Previous Events cleared (00) to associated devices of group 1, the value of parameter 1 is motion detection (0x08).

Sensor MultiLevel

This device supports 0x03 sensor type, i.e. brightness value, the valid range is 0~10000.

This device supports 0x01 sensor type, i.e. temperature value, accuracy is one decimal place, the valid range is -40~125, scale=0, unit is degree celsius, when the temperature sensor is malfunctioned, the reported value is 0x8000.

This device supports 0x05 sensor type, i.e. humidity value, the valid range is 0~100, when the humidity sensor is malfunctioned, the reported value is 0xFF.

Wake up interval

Available settings: 0 or 10~2678400

Interval Step: 10

Default setting: 7200 (every 2 hours)

The MultiSensor will wake up after each defined time interval, longer time interval means less frequent communication and thus a longer battery life. Wake up can also be performed manually by holding the action button for 1 second.

The sensor will send Wakeup Notification CC to Lifeline after wake up.

SUPPORTED COMMAND CLASS

| Command Class | Version | Required Security Class |
|---------------------------|---------|--------------------------------|
| Association | 2 | Highest granted Security Class |
| Association Group Info | 3 | Highest granted Security Class |
| Battery | 1 | Highest granted Security Class |
| Configuration | 4 | Highest granted Security Class |
| Device Reset Locally | 1 | Highest granted Security Class |
| Firmware Update Meta Data | 5 | Highest granted Security Class |
| Indicator | 3 | Highest granted Security Class |
| Manufacture Specific | 2 | Highest granted Security Class |
| Multi Channel Association | 3 | Highest granted Security Class |
| Notification | 8 | Highest granted Security Class |
| Sensor Multilevel | 4 | Highest granted Security Class |
| Powerlevel | 1 | Highest granted Security Class |
| Version | 3 | Highest granted Security Class |
| Wake Up | 2 | Highest granted Security Class |
| Security 0 | 1 | None |
| Security 2 | 1 | None |
| Supervision | 1 | None |
| Transport Service | 2 | None |
| Z-Wave Plus Info | 2 | None |

Basic Command Class mapping

Basic Command Class is not mapped to any of the supported command classes.

Configuration Command Class

| Parameter | Size | Description | Default Value |
|-----------|------|---|---------------|
| 2 | 1 | <p>Threshold value to send battery report.</p> <p>When battery power change value is over the threshold value, send Battery Report to Lifeline.</p> <p>Available settings: 1~50</p> | 10 |

| | | | |
|---|---|---|--------------|
| 3 | 2 | <p>Motion detection sensitivity.</p> <p>0: PIR sensor is disabled.</p> <p>8-255: PIR sensor is enabled. The lower the value, the more sensitive the PIR sensor is.</p> <p>Available settings: 0 & 8~255</p> | 15 |
| 4 | 1 | <p>Motion detection blind time (unit is 0.5S). PIR sensor is "blind" (insensitive) to motion after last detection for the amount of time specified in this parameter.</p> <p>Shorter time periods allow to detect motion more frequently, but the battery will be drained faster.</p> <p>Available settings: 0-15 (0.5-8 seconds, time [s] = 0.5 x (value+1))</p> | 15 |
| 5 | 1 | <p>Motion detection - pulse counter.</p> <p>This parameter determines the number of moves required for the PIR sensor to report motion. The higher the value, the less sensitive the PIR sensor is.</p> <p>It is not recommended to modify this parameter settings!</p> <p>Available settings: 0~3 0: 1 pulse 1: 2 pulses 2: 3 pulses 3: 4 pulses</p> | 1 (2 pulses) |
| 6 | 1 | <p>Motion detection - window time.</p> <p>Period of time during which the number of moves set in parameter 5 must be detected in order for the PIR sensor to report motion. The higher the value, the more sensitive the PIR sensor is.</p> <p>It is not recommended to modify this parameter settings!</p> <p>Available settings: 0~3 0: 4 seconds 1: 8 seconds 2: 12 seconds 3: 16 seconds</p> | 2 |
| 7 | 2 | <p>Motion detection - alarm cancellation delay.</p> <p>Time period after which the motion alarm will be cancelled in the gateway controller and associated devices. If there is no motion triggered during this period, the following commands will be sent to the associated devices:</p> <p>1) Send Notification to Lifeline(Notification Type is Home Security, Event is 0, Parameter 1 is Motion Detection Unknown Location)</p> <p>2) Send BASIC OFF to group 2, the value is defined by parameter 10.</p> <p>Any motion detected during this period resets the timer.</p> <p>Available settings: 3-28800 (in seconds)</p> | 30 |

| | | | |
|----|---|---|---------------|
| 8 | 1 | <p>BASIC command class configuration. This parameter determines the command frames sent to 2nd association group (assigned to PIR sensor).</p> <p>Available settings: 0~2</p> <p>0: Both BASIC On and OFF command frames sent in Basic Command Class</p> <p>1: Only the BASIC On command frame sent in Basic Command Class when motion event is triggered</p> <p>2: Only the BASIC OFF command frame sent in Basic Command Class when motion event is cleared</p> | 0 |
| 9 | 2 | <p>PIR Sensor - value of BASIC ON command sent to 2nd association group. This parameter determines value of BASIC ON command sent to 2nd association group when motion event triggered.</p> <p>Available settings: 0~99 & 255</p> | 255 |
| 10 | 2 | <p>PIR Sensor - value of BASIC OFF command sent to 2nd association group. This parameter determines value of BASIC OFF command sent to 2nd association group when motion event cleared.</p> <p>Available settings: 0~99 & 255</p> | 0 |
| 11 | 1 | <p>Motion detection - operating mode This parameter determines in which part of day the PIR sensor will be active.</p> <p>Available settings: 0~2</p> <p>0: PIR sensor always active 1: PIR sensor active during the day only 2: PIR sensor active during the night only</p> | 0 |
| 12 | 2 | <p>Motion detection - night/day This parameter defines the difference between night and day in terms of light intensity, used in parameter 11.</p> <p>Available settings: 1~32767 (1~32767 lux)</p> | 200 |
| 13 | 4 | <p>Illuminance report - interval Time interval between consecutive illuminance reports. The reports are sent based on the interval.</p> <p>Available settings: 5-2678400 (31 days = 31*24*3600=2678400)</p> <p>When the value is set as 0, the reports will not be sent periodically.</p> | 3600 (1 hour) |
| 14 | 2 | <p>Illuminance report - threshold This parameter determines the change in light intensity level resulting in illuminance report being sent to the main controller. (The change in light intensity will only be detected when the PIR is triggered or the time interval set in parameter 13 elapsed.)</p> <p>Available settings: 1~32767 (1~32767 lux)</p> <p>When the value is set as 0, the threshold does not work.</p> | 100 |

| | | | |
|----|---|--|-------------------------|
| 15 | 1 | <p>Associations in Z-Wave network Security Mode This parameter defines how commands are sent in specified association groups: as secure or non-secure. Parameter is active only in Z-Wave network security mode. It does not apply to 1st group "Lifeline".</p> <p>Available settings:</p> <p>0: 2nd group sent as un-secure 1: 2nd group sent as secure</p> | 1 |
| 16 | 4 | <p>Time interval to report temperature, humidity (unit is S) Temperature report and humidity report will be sent based on the time interval value periodically.</p> <p>Available settings: 5-2678400 (31 days = 31*24*3600=2678400) When the value is set as 0, the reports will not be sent periodically.</p> | 3600 (1 hour) |
| 17 | 2 | <p>Temperature sensor value change threshold (unit is 0.1 degree celsius) Report temperature value automatically when temperature change exceeds the threshold. (temperature change only detected when PIR is triggered or time of parameter 16 expires)</p> <p>Available settings: 0-255, value 0 means the threshold is disabled.</p> | 10 (1.0 degree celsius) |
| 18 | 2 | <p>Humidity sensor value change threshold Report humidity value automatically when humidity change exceeds the threshold. (humidity change only detected when PIR is triggered or time of parameter 16 expires)</p> <p>Available settings: 0-127, value 0 means the threshold is disabled.</p> | 5 (5%) |
| 19 | 2 | <p>Temperature compensation (unit is 0.1 degree celsius) Available settings: -1000~1000(-100°C~100°C)</p> | 0 |
| 20 | 1 | <p>Humidity compensation Available settings: -100~100</p> | 0 |

Note: the "read only" parameters can only be read, and can not be set.

Physical Installation

Method 1: Stick 3M glue on the back of the bracket and then stick the bracket to the wall

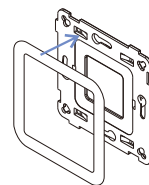

Method 2: Screw the bracket to the wall

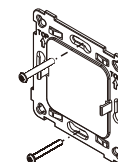

After the bracket is fixed, clip the frame and control part to the bracket in sequence

