



# HEATIT Z-TEMP3

 PRODUCT DOCUMENTS 	
Firmware version <b>FW 1.0</b>	Document version <b>2024-A</b>
Article no. <b>45 126 90</b> <b>45 126 91</b>	Document date <b>01.07.2024</b>

Org. doc. date 01.07.2024

## Installers manual

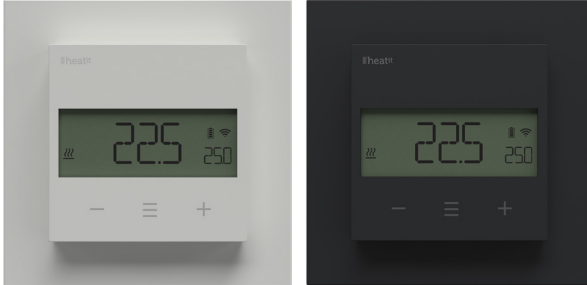

White, RAL 9003  
45 126 90

Black Matt  
45 126 91

## TABLE OF CONTENTS

1. Introduction
2. Statement regarding products from multiple manufacturers
3. Behavior within the Z-Wave network
4. Quick Start
5. Connections
6. Installation
7. Add/Remove
8. Factory Reset
9. Startup
10. Principles of regulation
11. Local settings menu
12. Display Menu structure
13. Temperature shown in display
14. Standby and main screen
15. Calibration
16. Brightness
17. Display on/off
18. Display icons
19. Child lock
20. Open window detection
21. Error codes
22. QR-Code Placement (DSK)
23. Security
24. Node Information Frame
25. Associations
26. Association Groups
27. Configuration Parameters
28. Command Classes
29. Supported Command Classes
30. Controlled Command Classes
31. Thermostat dimensions
32. Thermostat controls
33. Order of assembly
34. Chart - Display Menu Product info

## 1. INTRODUCTION

Heatit Z-Temp3 is a battery-operated thermostat designed for controlling waterbased heating systems. Used in combination with the Heatit Z-Water2, you can control your heating system through the Z-Wave® network or via the buttons on the front panel. The thermostat has a user-friendly interface.

Heatit Z-Temp3 has 3 modes: Heat, Cool, and Eco.

The thermostat fits into System 55 frames, and may be mounted alongside other equipment such as e.g dimmers or light switches. Heatit Z-Temp3 can also be mounted directly on the wall or placed freely, e.g. on a shelf.

Heatit Z-Temp3 can be set as a master thermostat. This means that you can set the setpoint and mode on one unit, and it will automatically send the setpoint and mode to other connected units.

All communication between Heatit Z-Temp3 and the controlled device is 100% wireless.

Heatit Z-Temp3 uses 2x AAA batteries, but you can also connect the device to an external power source. The Heatit Transformer 230VAC (45 126 48) is recommended for this purpose.

Heatit Z-Temp3 can be associated with Heatit ZM Single Relay, other Z-Wave relays, Heatit ZM Thermostat, Heatit Z-TRM6 Thermostat and other Z-Wave devices to control other types of heating solutions.

Heatit Z-Temp3 is a great choice for the restoration or renovation of existing buildings, as it is easy to install without the need for wiring. We recommend using multiple 230VAC devices to create a mesh network.

## 2. STATEMENT REGARDING PRODUCTS FROM MULTIPLE MANUFACTURERS

### Please read this before installation

This device may be used with all devices certified with the Z-Wave Plus® certificate and should be compatible with such devices produced by any manufacturer. Every primary controller is different depending on the manufacturer, their target audience and intended use/application. Please review the functionalities implemented by the primary controller you intend to use with our Z-Wave Plus certified device to ensure that it provides the necessary controls to take full advantage of our product's capabilities.

## 3. BEHAVIOR WITHIN THE Z-WAVE NETWORK

This device may be operated within any Z-Wave® network with Z-Wave-certified devices from other manufacturers. All non-battery-operated nodes within the network will act as repeaters regardless of manufacturer to increase the reliability of the network. On delivery, the device does not belong to any Z-Wave network. The device needs to be added to an existing network to communicate with the other devices within it. Devices may also be removed from a network. The add/remove processes are initiated by the primary controller of the Z-Wave network.

## 4. QUICK START

1. Insert the batteries or alternatively connect the cable supplied with the Heatit Transformer 230VAC (Art. no. 45 126 48).
2. Mount the device directly on the wall or on a junction box.
3. If using a power supply instead of batteries, Connect the wires according to the description in Chapter "Connections". Turn on the voltage.
4. Set the primary controller in add mode (security/non-security).
5. Hold the Center button until "OFF" is shown in the display (approx. 5 seconds).
6. Press the "+" button once to reach "CON", and hold the middle button "≡" until the display shows a rotating pattern.
7. The thermostat will display "INCL" when the thermostat is successfully added.

NB! If adding/removing fails, Err (error) will appear.

## 5. CONNECTIONS

The Heatit Z-Temp3 can be connected to a 2.7 to 3.3VDC power supply via the optional cable, providing an alternative to using batteries. The cable is supplied with the Heatit Transformer 230VAC (Art. no. 45 126 48).

To access the batteries and power connector, or to mount the device, hold the sides of the display and gently pull outwards to detach the thermostat from the mounting plate.

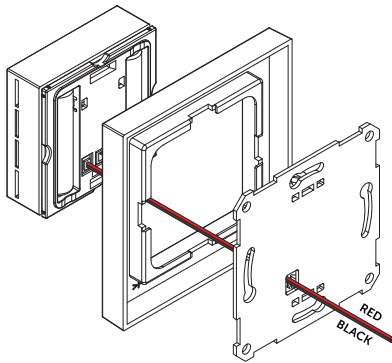

Red cable 3VDC  
Black cable 0VDC

## 6. INSTALLATION

Remove the thermostat from the frame and mounting plate. Insert the 2x AAA batteries in the thermostat or connect the connector on the back using the optional cable. The thermostat offers versatile installation options, allowing it to be mounted on a wall, on a junction box or placed at a preferred location. For wall mounting, attach the mounting plate using either screws or double-sided tape. If mounting on a junction box, use screws. Once the mounting plate is in place, carefully push the thermostat back onto the mounting plate.

NB! Be careful when installing the batteries, ensuring their polarity matches the indented markings on the plastic.

## 7. ADD/REMOVE

### Please read this before installation

The primary controller/gateway has a mode for adding or removing devices. Please refer to your primary controller manual on how to set the primary controller in add/remove mode. The device may only be added or removed from the network if the primary controller is in add/remove mode. When the device is removed from the network, it will NOT revert to factory settings.

Adding the device within a 2 meter range from the gateway can minimize faults during the Interview process.

Note: The Heatit Z-Temp3 does not stay in Learn mode until it is included.

There are two ways to add the device to a Z-Wave network.

### 7.1 Method 1: Standard (Manual)

Add/remove mode is indicated on the device by rotating LCD segments on the display. It indicates this for 90 seconds until a timeout occurs, or until the device has been added to/removed from the network. Configuration mode can also be cancelled by performing the same procedure used for starting Configuration mode.

1. Hold the Center button for 5 seconds. The display will show "OFF".
2. Press the "+" button once to see "CON" in the display.
3. Start the add/remove device process in your primary controller.
4. Start the configuration mode on the thermostat by holding the Center button for approximately 2 seconds.

The device is now ready for use with default settings.

NB! When the device is removed from the gateway, the parameters are not reset. To reset the parameters, see Chapter "Factory reset".

If inclusion fails, please perform a "remove device" process and try again. If inclusion fails again, please see "Factory reset".

### 7.2 Method 2: SmartStart (Automatic)

SmartStart enabled products may be added to a Z-Wave network by scanning the Z-Wave QR-Code on the product if your primary controller supports SmartStart inclusion. No further action is required and the SmartStart product will be added automatically after being powered on within range of the primary controller.

## 8. FACTORY RESET

Enter the menu by holding the Center button for about 5 seconds, navigate in the menu with the "+" button til you see FACT. Press the Center button until you see "-- --" blinking in the display, then hold for about 5 seconds to perform a reset. You may also initiate a reset by holding the Right and Center buttons for 55 seconds.

When either of these procedures has been performed, the thermostat will perform a complete factory reset. The device will display "RES" for 5 seconds while performing a factory reset. When "RES" is no longer displayed, the thermostat has been reset.

Please use this procedure only when the primary controller is missing or otherwise inoperable.

## 9. STARTUP

After powering up the device for the first time, all parameters will have default settings.

## 10. PRINCIPLES OF REGULATION

The thermostat uses temperature readings retrieved from the internal sensor to regulate the temperature. The thermostat will regulate the temperature using hysteresis or PWM, based on the setpoint temperature.

To select either "HYST" or "PWM" you can find the "REG" menu option or use Parameter 5 "Regulation mode."

### 10.1 Hysteresis

Hysteresis will turn on and off the load based on the hysteresis value in comparison to the setpoint. You can make changes to the thermostat hysteresis. You may choose hysteresis values between 0.3°C and 3.0°C using Parameter 7. The default setting is 0.5°C. When using waterbased heating we recommend a hysteresis of 1.0°C.

You may also change the hysteresis by entering the local settings menu and holding the Center button for 2 seconds when "REG" is displayed. Here you can choose values between 0.3 and 3.0.

### 10.2 Pulse-width modulation PWM

With PWM regulation enabled, the thermostat will regulate based on duty cycles. The thermostat is turned on and off in percentage intervals of the cycle. The amount of time the relay will be on is based on how far the measured temperature is from the setpoint.

## 11. LOCAL SETTINGS MENU

To enter the settings menu, hold the Center button for 5 seconds. The display will display "OFF". You are now in the settings menu. While in the settings menu, "SET" will be displayed in the bottom right of the display. You can now scroll up and down using the Left and Right buttons. Some options have submenus. To navigate the submenus, press the Center button once to enter or exit the submenu. Press the Left and Right buttons to find your desired value and hold the Center button for 2 seconds to confirm your selection. "STOR" will appear to indicate settings are stored.

## 12. DISPLAY MENU STRUCTURE

See flowchart at the end of this manual.

## 13. TEMPERATURE SHOWN IN DISPLAY

By default, the temperature shown on the display while in standby state is the setpoint. This may be altered with Parameter 8: "Temperature display". It may also be changed by entering the local settings menu and holding the Center button for 2 seconds when "MODE" is displayed. You can choose between "SETT" and "RELT". "SETT" is the Setpoint temperature and "RELT" is the real-time temperature.

## 14. STANDBY AND MAIN SCREEN

When the thermostat remains untouched for a while, it will automatically go to the standby screen. The standby will by default show the setpoint temperature.

By pressing any button once, you will see the measured temperature. By pressing the Left or Right button multiple times, you will change the setpoint.

## 15. CALIBRATION

If the temperature sensor readout is not correct, you can make minor changes to the temperature readout. The temperature readings can be calibrated by  $\pm 6^{\circ}\text{C}$  using Parameter 4. The calibration can also be performed from the menu using CAR. The adjusted value will be displayed in the controller/gateway indicating what the thermostat uses for regulation.





## 16. BRIGHTNESS

Using the menu choice "BR1", the brightness of the display in Active state can be changed. "BR1" is also included in the device as Parameter 9 (BR1).

## 17. DISPLAY ON/OFF (DON/DOFF)

The thermostat has a display ON/OFF function which decides whether the display should turn completely off when in Standby. To enable/disable this function, hold the Left and Center buttons for 10 seconds. The display will show "DOFF" when the function is activated and "DON" when the function is disabled. When operating any button, the display will light up.

## 18. DISPLAY ICONS

ICON	DESCRIPTION
	This icon will be displayed while the relay is on and the thermostat is in either Heating or Eco mode.
	This icon will be displayed while the relay is on and the thermostat is in Cooling mode.
	This icon shows the current signal strength.
	This icon shows the battery status.

## 19. CHILD LOCK

The child lock function disables the buttons on the display, preventing local access and operation. It will show "LOCK" when attempting to operate it while the function is enabled. To enable or disable the function, hold the Left and Right buttons for 10 seconds. Enabling the function will show "LOCK" in the display, disabling the function will show "OPEN".

## 20. OPEN WINDOW DETECTION OWD

Open Window Detection (OWD) is a function which will reduce the thermostat setpoint on detection of an open window. This happens when the temperature sensor registers a rapid temperature drop.

When OWD is active, the setpoint is reduced to 5°C in order not to waste energy. OWD will automatically be cancelled if OWD has been active for more than 1 hour, or if the temperature increases by 3°C. OWD can also be cancelled manually by increasing/decreasing the setpoint with the Left and Right buttons.

By default, OWD is not enabled. The feature may be enabled by selecting "OWD" from the menu. Choose between options "OFF" and "ON". It can also be enabled by setting Parameter 18 (Open window detection) to 1.

## 21. ERROR CODES

Err Adding fail. See Chapter 7 "Add/remove".

Err1 Internal error. Most probably a faulty unit. Contact support.

Err2 Z-Wave error. Most probably a faulty unit. Contact support.

Err3 Internal error. Most probably a faulty unit. Contact support.

## 22. QR-CODE PLACEMENT (DSK)

The QR-Code is needed when including a device using S2 security or SmartStart. The DSK can be found in the QR-Code and is located;

- On the product.
- In the Quick Guide.
- On the packaging box/gift box.

## 23. SECURITY

S2 security enhances Z-Wave Plus with an additional layer of AES 128-bit encryption of the wireless Z-Wave communication to prevent hacking and man-in-middle attacks on the home network.

This device supports S2 and has a Z-Wave DSK QR-Code label that may be used when the device is added to the Z-Wave home network. The primary controller will ask for a 5-digit code. They are the first underlined 5 digits located on the QR code sticker. The primary controller will then ask you to confirm the rest of the code that is contained in the QR-Code.

## 24. NODE INFORMATION FRAME

The node information frame is the "business card" of a Z-Wave device. It contains information about the device type and its technical features. The add and remove procedure of the device is confirmed by sending out a node information frame. Besides this, it may be necessary for certain network operations to send out a node information frame.

## 25. ASSOCIATIONS

Z-Wave devices interact with other Z-Wave devices. The relationship between one device controlling another device is called an association. In order to control a subordinate device, the controlling device needs to maintain a list of devices that will receive controlling commands. These lists are called "Association Groups". They are always related to the specific event triggered (e.g., sensor reports). In case the event is triggered, all devices stored in the respective association group will receive a joint wireless command.

### 25.1 Setting and Removing Associations

Associations may be assigned and removed via Z-Wave commands. Please refer to your primary controller/Z-Wave gateway for more information.

## 26. ASSOCIATION GROUPS

MULTI LEVEL SWITCH DEVICE	DESCRIPTION
Group 1	Lifeline. Lifeline Group to be used by primary controller, sends: - Thermostat Operating State - Thermostat Setpoint Report - Thermostat Mode Report - Sensor multilevel Report - Device Reset Locally - Battery Report - Protection Report - Configuration Report Max nodes in group: 1

MULTI LEVEL SWITCH DEVICE	DESCRIPTION
Group 2	Binary Switch Set. Send Binary Switch set commands based on the internal relay state, sends: - Binary Switch Set Max nodes in group: 10
Group 3	Thermostat Setpoint set. Sends Thermostat Setpoint set commands based on own setpoint to allow for use as master thermostat, sends: - Thermostat Setpoint Set Max nodes in group: 10
Group 4	Thermostat Mode set. Sends Thermostat Mode set commands based on own mode to allow for use as master thermostat, sends: - Thermostat Mode Set Max nodes in group: 10

If the thermostat is to control a relay, an association from Group 2 must be created from the thermostat to the relay that is to be controlled.

Disclaimer: When using the Heatit Z-Temp3 to control multiple relays on a Heatit Z-Water (Art. no. 4512475) or a Heatit Z-Water2 (Art. no. 4512495), only use relays 1 through 7. Do not use relays 8, 9, or 10 for this purpose.

If the thermostat is to control other thermostats as a master thermostat, an association from Group 3 and Group 4 must be created from the master thermostat to the thermostats to be controlled.

## 27. CONFIGURATION PARAMETERS

Z-Wave products are supposed to work out of the box after inclusion. Some device configuration may, however, alter the functionality to better serve user needs or unlock further enhanced features. All the parameters below do not feature altering capabilities, advanced or read only flags.

PARA. NO#	PARA. SIZE (BYTE)	NAME	SHORT DESCRIPTION / COMMENT	MIN	MAX	DEFAULT	DESCRIPTION OF VALUE
1	1	Disable buttons	Disable buttons, must be enabled through the parameter, or turned back on locally by holding the center and right button for 30 seconds until the display shows "UNLK."	0	1	0	Enabled, buttons on the front of the device work. (Default) Disabled, buttons on the front of the device are disabled.
2	2	Minimum temperature limit (ALO)	Decides the lowest temperature allowed by the thermostat	50	400	50	5°C to 40°C (Default is 5°C)
3	2	Maximum temperature limit (AHI)	Decides the highest temperature allowed by the thermostat	50	400	400	5°C to 40°C (Default is 40°C)
4	1	Calibration (CAR)	Manually calibrate sensor A ±6°C	-60 (195)	60 (60)	0	-6.0°C to 6.0°C. Calibrates the sensor by ±6°C. (Default is 0°C) NBI! To set a negative value, use 256 and subtract the desired value.
5	1	Regulation mode (REG)	Choose between regulation modes PWM and Hysteresis.	0	1	0	Hysteresis PWM regulation
6	2	Thermostat state update interval	Set the time interval of how often the device updates Thermostat Setpoint set, Thermostat Mode set and Binary set to associated devices.	150	65535	3600	Sends only when changed. 150 to 65535 seconds. 43200 seconds + when changed. (Default)
7	1	Temperature control hysteresis (HYST)	Choose the hysteresis used when regulation mode is set to HYST.	3	30	5	0.3°C to 3.0°C. Default is 5 (0.5°C)
8	1	Temperature display	Select what is shown on the display during Standby state.	0	1	0	Display setpoint temperature. (Default) Display measured temperature.
9	1	Active display brightness (BRI)	Configure the brightness of the display during active state.	1	10	10	10 to 100% (Default 100%)

PARA NO#	PARA SIZE (BYTE)	NAME	SHORT DESCRIPTION / COMMENT	MIN	MAX	DEFAULT	DESCRIPTION OF VALUE
10	2	Temperature report interval	Set the time interval between consecutive temperature reports.	150	65535	990	150 to 65535 seconds. 990s (16.5 min) (Default)
11	1	Temperature report hysteresis	Set the change in temperature required to send a temperature report based on change.	1	100	10	0.1°C to 10°C. 10 (1°C) (Default)
12	2	Humidity report interval	Set the time interval between consecutive humidity reports.	150	65535	990	150 to 65535 seconds. 990s (16.5 min) (Default)
13	1	Humidity report hysteresis	Change in humidity required to send a report	10	100	25	10% to 100%. 25% (Default)
14	2	Heating setpoint	Set setpoint for Heating mode	50	400	210	5°C to 40°C. 21°C (Default)
15	2	Cooling setpoint	Set setpoint for Cooling mode	50	400	250	5°C to 40°C. 25°C (Default)
16	2	ECO setpoint	Set setpoint for ECO mode	50	400	180	5°C to 40°C. 18°C (Default)
17	1	Operating Mode (MODE)	Set the thermostat mode.	0	1	OFF Thermostat will not operate	
				1		Heating mode (Default)	
				2		Cooling mode	
				3		ECO mode	
18	1	Open window detection	Choose to enable or disable the Open windows detection.	0	0	Open window detection disabled. (Default)	
				1		Open windows detection enabled.	

## 28.COMMAND CLASSES

Additional information regarding Command Classes and their functionality:

### 28.1 Basic Command Class

A Basic command to the device will change the thermostat mode. Uses the following values:

0x00 = OFF (0x00)

0xFF = HEAT (0x01)

If the thermostat is in ECO or COOL mode, 0x00 will still change the mode to OFF. ECO or COOL cannot be enabled with a Basic Set command.

### 28.2 Protection Command Class

Protection Command Class allows you to disable local control of the thermostat, this is separately from the Child Lock function.

To enable the Protection Command Class, either set Parameter 1 (disable buttons) to value 1, enabling Local Protection State 0x02, or send a Protection Set with Local Protection State 0x01 or 0x02.

During Protection State 0x01, the device is protected by a button sequence and allows for no local operation until it is unlocked. To unlock the thermostat while in Protection state 0x01, first press twice on the Left button, then press twice on the Right button and then finally twice on the Center button. This will unlock the thermostat until it goes back to standby, requiring you to unlock it again.

Protection State to 0x02 means that no operation is possible and the thermostat can only be unlocked by setting Parameter 1 to 0, or by holding the Center and Right buttons for 30 seconds.

### 28.3 Thermostat Setpoint Command Class

Thermostat Setpoint is implemented with 3 setpoints, Heating, Cooling and ECO. Supported setpoints are from 5°C - 40°C with 0.5°C increments.

### 28.4 Thermostat Mode Command Class

It is possible to change the operating mode of the thermostat by sending a Thermostat Mode set command. The accessible operating modes are:

0x00: OFF (Thermostat regulation and display are deactivated).

0x01: Heating Mode (Thermostat regulation is active).

0x02: Cooling Mode (Thermostat regulation is inverted).

0x0B: ECO Mode (Thermostat regulation is active with a separate setpoint from Heating Mode).

### 28.5 Thermostat Operating State Command Class

The thermostat reports the operating state of the associated device using this Command Class.

0x00 = Idle

0x01 = Heating (used for Heating and ECO mode)

0x02 = Cooling

### 28.6 Indicator Command Class

The device supports the Indicator Command Class. The indicator Command Class will flash the backlight of the display.

### 28.7 Battery Command Class

The device uses the battery Command Class to report its current battery level.

The battery level is reported in three instances: upon inclusion into a Z-Wave network, when the battery level has changed by more than 10%, and following a repower of the device.

### 28.8 Binary Switch Command Class

Binary Switch commands are used to control external relays associated with group 2.

Uses the following values:

0x00 = OFF

0xFF = ON

This Command Class is based on the operating state of the thermostat.

## 29.SUPPORTED COMMAND CLASSES

The following table lists all Command Classes supported by the Z-Wave device. The device supports S0, S2 Authenticated security and S2 Unauthenticated security.

ASSOCIATION	VERSION	INSECURE ON SECURE INCLUSION	SECURE ON SECURE INCLUSION
Association	v2		Yes
Association Group Information	v3		Yes
Battery	v1		Yes
Device Reset Locally Notification	v1		Yes
Firmware Update MD	v5		Yes
Indicator	v3		Yes
Manufacturer Specific	v2		Yes
Multi channel Association	v3		Yes
Power level	v1		Yes
Security	v1	Yes	
Security v2	v1	Yes	
Supervision	v1	Yes	
Transport Service	v2	Yes	
Version	v3		Yes
Z-Wave Plus Information	v2	Yes	

ASSOCIATION	VERSION	INSECURE ON SECURE INCLUSION	SECURE ON SECURE INCLUSION
Configuration	v4		Yes
Basic	v2		Yes
Sensor Multilevel	v11		Yes
Protection	v1		Yes
Thermostat Mode	v3		Yes
Thermostat Operating State	v1		Yes
Thermostat Setpoint	v3		Yes

### 30. CONTROLLED COMMAND CLASSES

ASSOCIATION	VERSION	INSECURE ON SECURE INCLUSION	SECURE ON SECURE INCLUSION
Binary Switch	2		Yes

### 31. THERMOSTAT DIMENSIONS

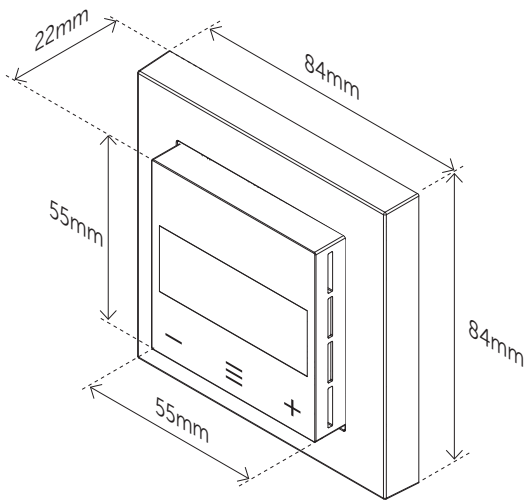

### 32. THERMOSTAT CONTROLS

ICON	DESCRIPTION
—	Previous. Decrease set temperature.
≡	Menu confirm. Menu enable.
+	Next. Increase set temperature.

### 33. ORDER OF ASSEMBLY

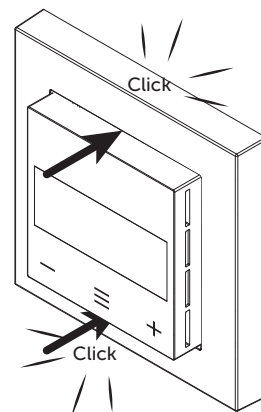
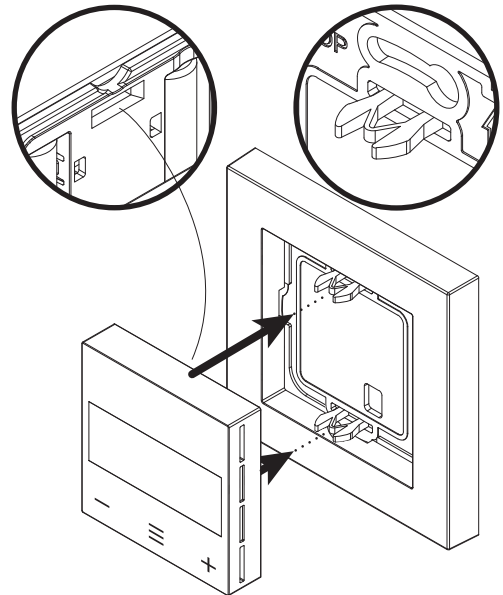
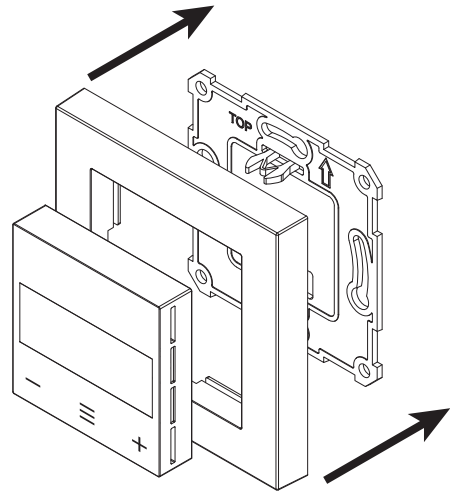



### 34.CHART - DISPLAY MENU STRUCTURE

Hold the middle button for 5 seconds to enter menu.

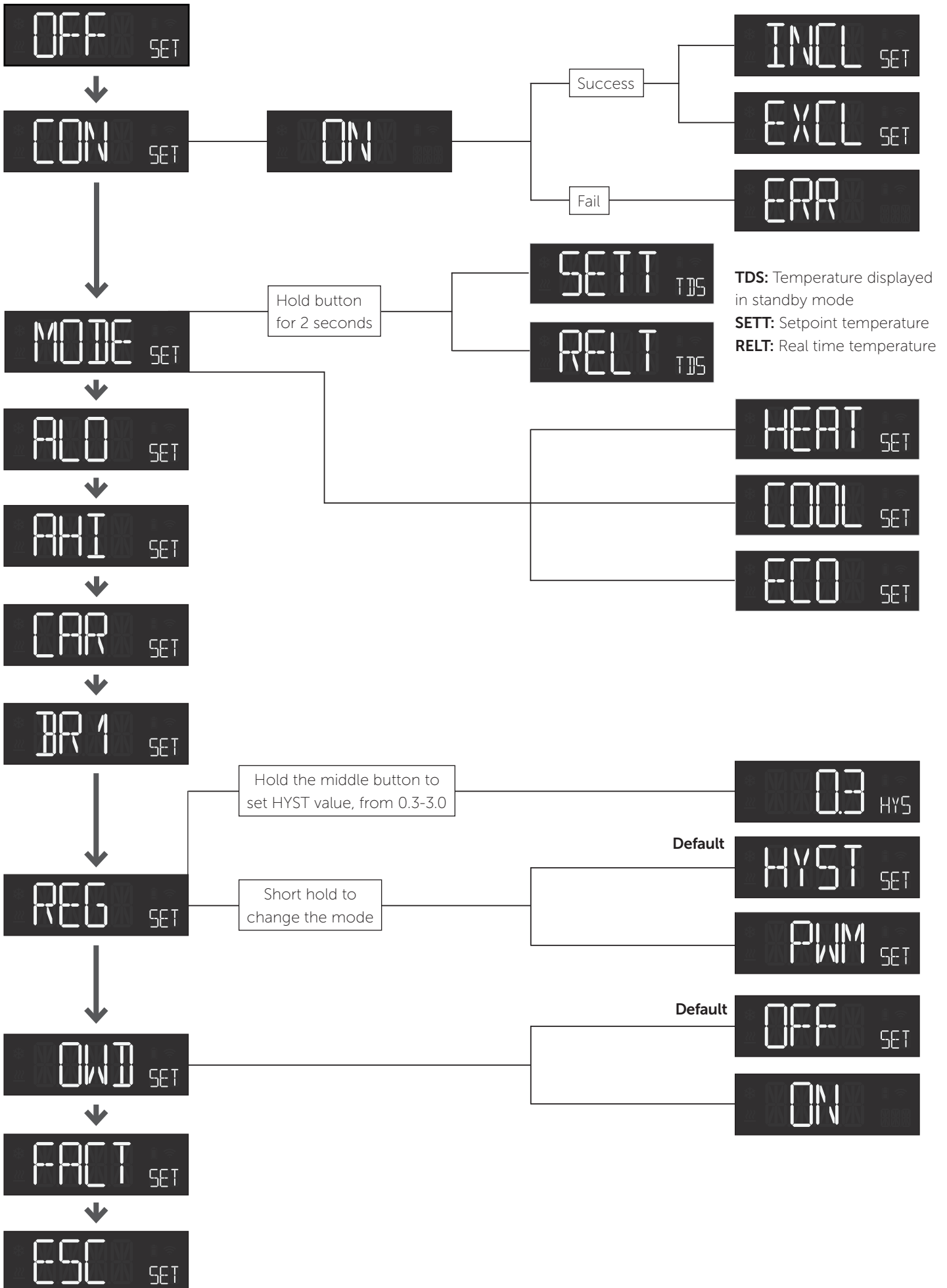

### 34.1 Error messages in display



**Failed to include**



**Internal error:**  
MCU and Z-Wave chip communication failed



**Z-Wave error**



**Internal sensor error**

### 34.2 General display messages



**Childlock activated**



**Childlock disabled**



**Display stays ON when in standby**



**Turn display OFF when in standby**



**Open window detection**



**Settings stored**

## PRODUCT INFO Heatit Z-Temp3

### FEATURES

- Z-Wave 800 series
- Battery-operated thermostat for controlling relays and thermostats
- Internal temperature sensor
- Humidity sensor
- Master thermostat
- 3 modes: Heat - Cool - Eco
- Supports encryption mode: S0, S2 Authenticated Class, S2 Unauthenticated Class
- Hysteresis - PWM
- Open Window Detection
- 10 associations per group
- LCD screen with backlight
- Lock mode/child lock
- Firmware update (OTA)
- SmartStart

The product must be used with a security-enabled Z-Wave controller in order to fully utilize security/encryption.

### TECHNICAL DATA

Protocol	Z-Wave, 868.4MHz
Chip	Z-Wave 800 chip
Rated voltage	2.7VDC to 3.3VDC
Battery	2x AAA
Power consumption	<1W
Ambient temperature	5°C to 40°C
Temperature range	5°C to 40°C
Storage temperature	-30°C to 70°C
Hysteresis	0.3°C to 3.0°C (Default 0.5°C)
Humidity	10% to 85% RH
Range RF	Min. 40 meter
IP Code	IP21
Size (LxWxH)	84 x 84 x 22mm

Approvals	Z-Wave Plus v2, CE, Reach, RED, RoHS
-----------	--------------------------------------

### MAINTENANCE

The device is maintenance-free. Indoor use only.

### DISPOSAL GUIDELINES

Do not dispose of electrical appliances as unsorted municipal waste, use separate collection facilities. Contact your local government for information regarding the collection systems available. If electrical appliances are disposed of in landfills or dumps, hazardous substances can leak into the groundwater and get into the food chain, damaging health and well-being.



We have designed this product in accordance with our strict quality requirements (ISO 9001) and environmental requirements (ISO 14001). All electrical installations must be carried out by an authorized electrical installer. The product must be installed in accordance with our installers manual and national building codes. Any wrongful installation, misuse or damage to the product is not covered under warranty.

Heatit Controls AB can not be held liable for any type of errors or omissions in our product information. Product specifications may change without further notice.



Heatit Controls AB • Läkarvägen 4, 454 31 BRASTAD, SWEDEN

Phone: +47 61 18 77 77 • post@heatit.com • [heatit.com](http://heatit.com)