

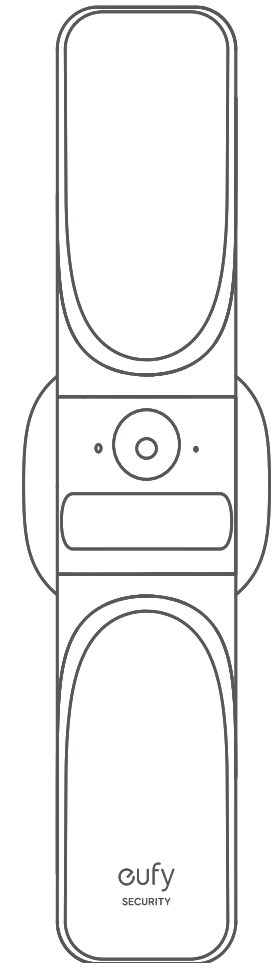

USER MANUAL

S100 Wall Light Cam

BENUTZERHANDBUCH
MANUAL DE USUARIO
MANUEL D'UTILISATION
MANUALE UTENTE
GEBRUIKERSHANDLEIDING
MANUAL DO UTILIZADOR
دليل المستخدم



Anker Innovations Limited. All rights reserved. eufy Security and eufy Security Logo are trademarks of Anker Innovations Limited, registered in the United States and other countries. All other trademarks are the property of their respective owners.

English	01
Deutsch	09
Español	17
Français	25
Italiano	33
Nederlands	41
Português	49
لَعَرَبِيَّة	57

AT A GLANCE

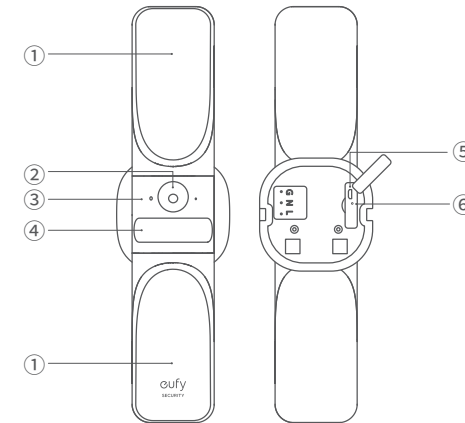

- ① Light
- ② Camera Lens
- ③ Status LED
- ④ Motion Sensor
- ⑤ Micro-USB Port
- ⑥ Reset Hole

WHAT'S INCLUDED



S100 Wall Light Cam



Mounting Base

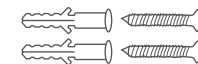

Base Screw



Camera Fixing Screw



USB Cable



Quick Start Guide

SETTING UP THE SYSTEM

1. Open the USB port cover on the back of the device, then connect it to power with the provided cable. The status LED will display red when the device is ready for setup.

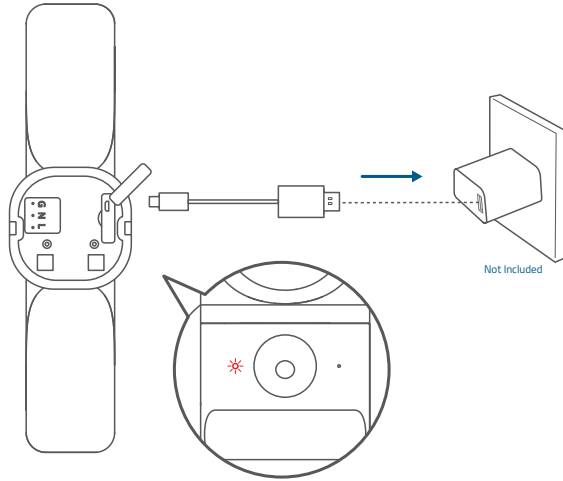

⚠ The main lights will not function while the device is powered via the USB port.

2. Download and install the eufy Security app, then set up an account.

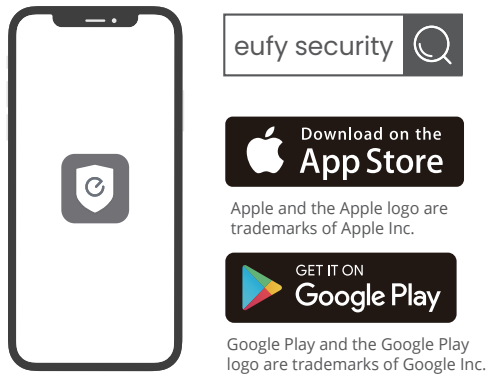

3. Scan the QR code on the back of the device or Quick Start Guide, then follow the on-screen instructions to complete the setup.

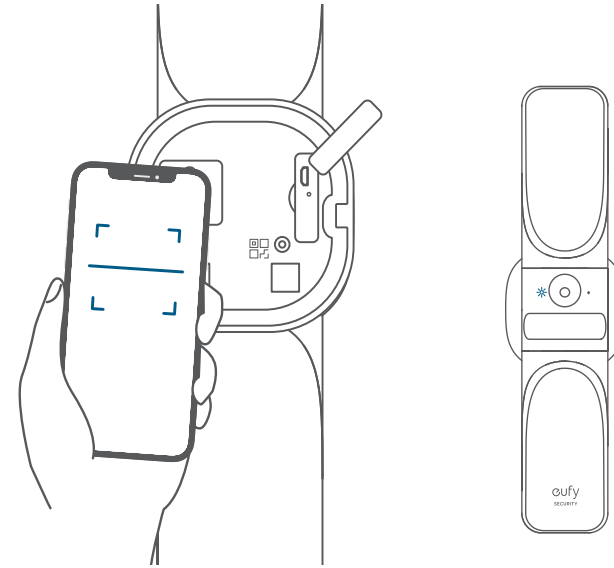

4. Disconnect the device from power and close the USB port cover, then secure the rubber plugs.

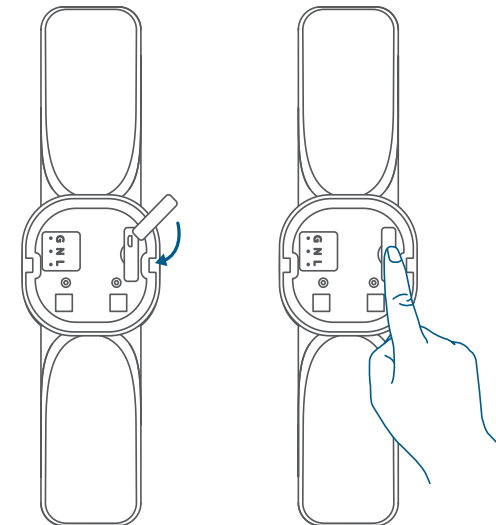

INSTALLATION



To avoid the risk of shock, injury, or death, always be cautious when working with electricity. Hire a professional electrician if you're uncomfortable working with electrical wiring.

1. Turn off the circuit breaker of your home. Turn the lights on and off to check the electricity in your home is properly turned off.

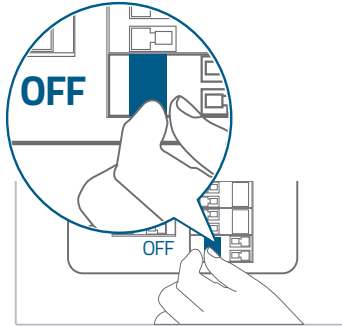

2. Select and mark the installation location on a flat section of wall.

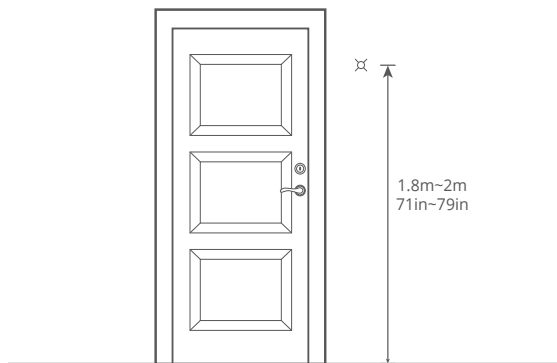

For the best motion detection experience:

- Make sure the device is located on a flat surface and the device is installed parallel to the wall. Do not install the device with an upward or downward tilt.
- Install the device between 1.8m/71in and 2m/79in above ground level of the motion detection area. Do not install the device more than 2.2m/87in above the ground.

3. If there is a mount from a previous light, remove it before continuing.

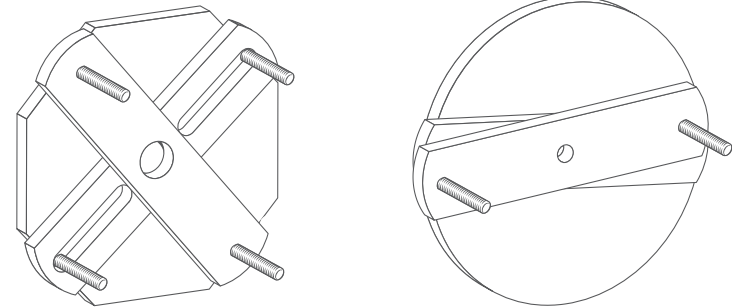

4. Screw the mounting bracket onto the wall.

- On wooden walls, do not pre-drill holes. Use the screws provided to fix the mounting bracket onto the wall.
- For walls made of hard materials, such as stucco, brick, or concrete, pre-drill holes in the required locations, insert the provided anchors, and then use the provided screws to fix the mounting bracket to the wall.

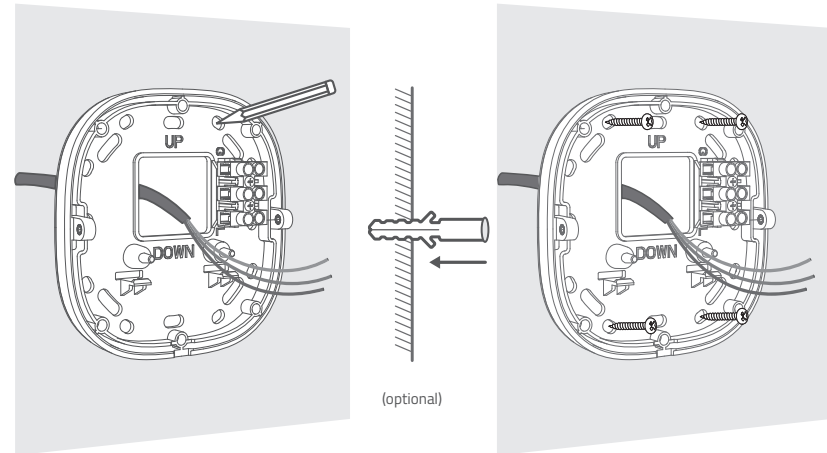

5. To avoid difficulty when mounting the device onto the mounting bracket:

- Make sure the wires are not too thick.
- Try to bend the wires at a 90° angle.

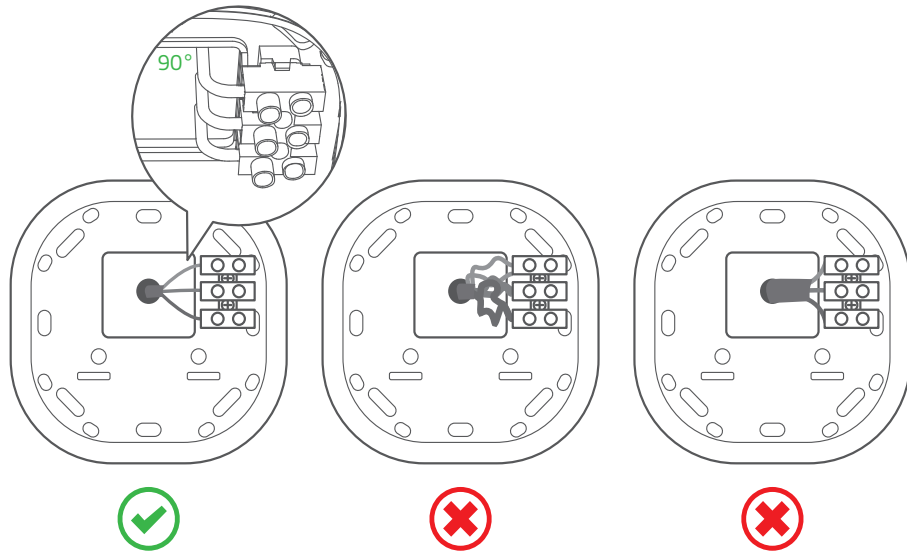

6. Loosen the wire screws, insert the neutral, ground, and live wires into the connectors, and then tighten the wire screws to thoroughly secure the wires.

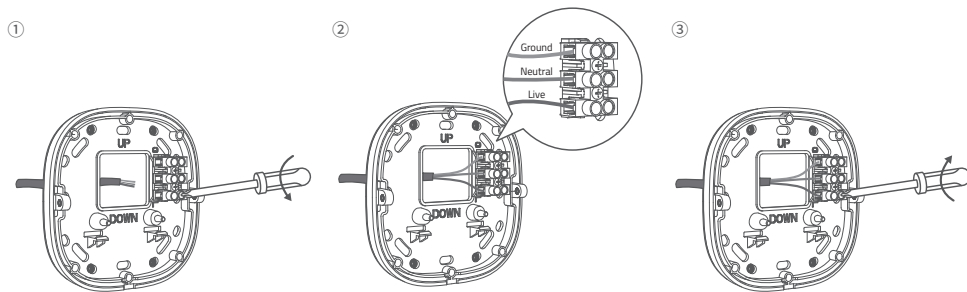

	North America	Europe
Ground	Green / Yellow	Green / Yellow
Neutral	White	Blue
Live	Black	Brown

 The wire colors vary depending on region.

7. Mount the device onto the mounting bracket, and then secure it with a screw on each side.

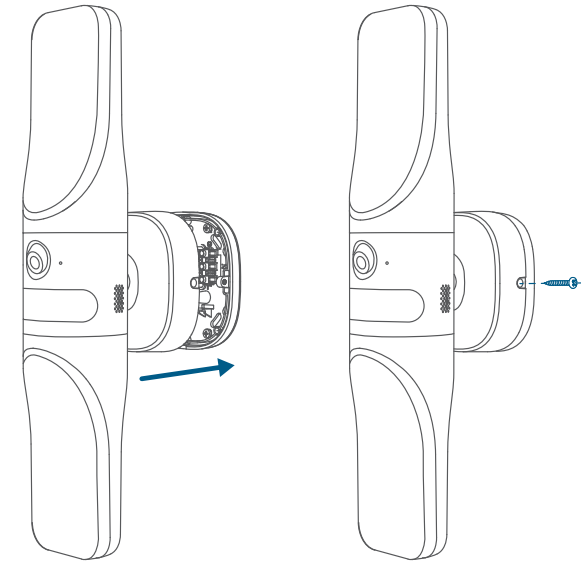

8. Turn on the circuit breaker of your home.

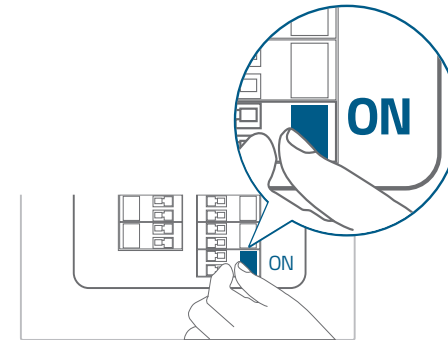

ADJUSTING ANGLES

1. Turn the device while checking the live stream from the eufy Security app until you get the desired view.

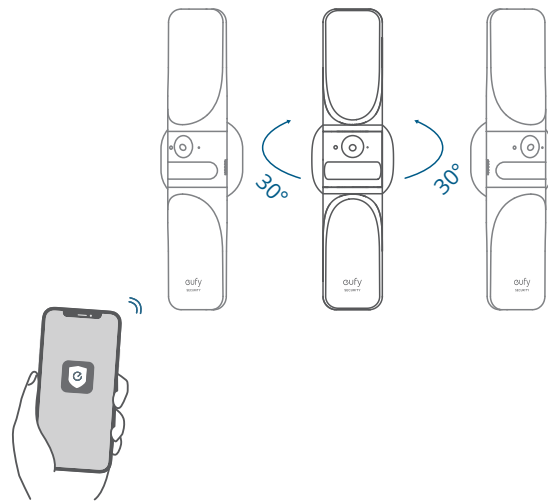

2. Turn the light to find the best angle to light your space.

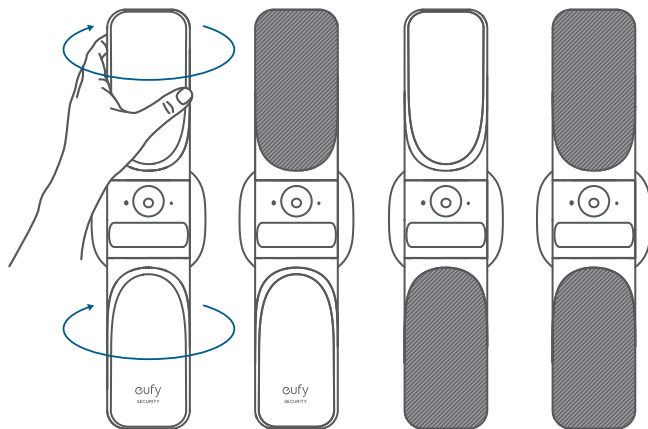

AUF EINEN BLICK

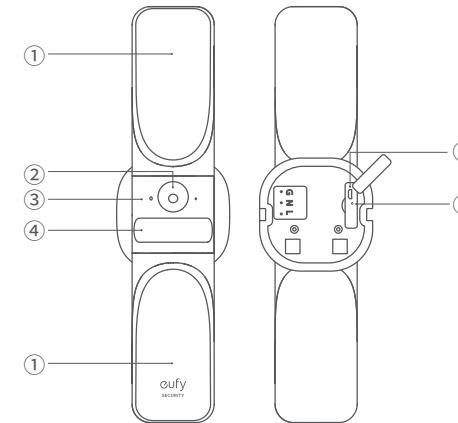

- ① Lampe
- ② Kameraobjektiv
- ③ Status-LED
- ④ Bewegungssensor
- ⑤ Micro-USB-Anschluss
- ⑥ Zurücksetz-Öffnung

IM LIEFERUMFANG



Wandlicht-Kamera
S100



Halterung

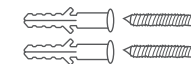

Basisschraube



Schraube zum
Befestigen der Kamera



USB-Kabel



KURZANLEITUNG

Einrichten des Systems

1. Öffnen Sie die Abdeckung des USB-Anschlusses auf der Rückseite des Geräts, und schließen Sie es mit dem mitgelieferten Kabel an die Stromversorgung an. Die Status-LED leuchtet rot, wenn das Gerät für die Einrichtung bereit ist.

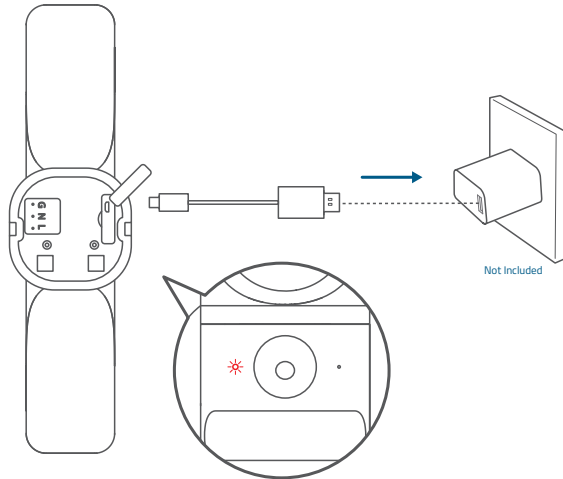

⚠ Das Hauptlicht funktioniert nicht, wenn das Gerät über den USB-Anschluss mit Strom versorgt wird.

2. Laden Sie die eufy Security-App herunter und richten Sie anschließend ein Konto ein.

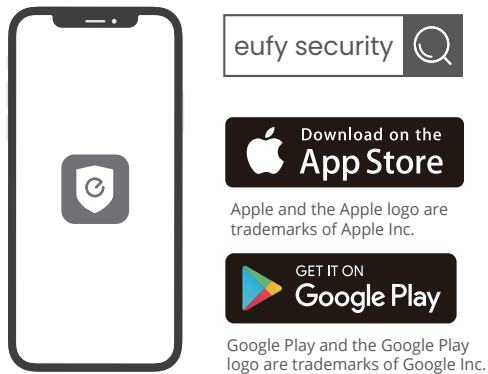

3. Scannen Sie den QR-Code auf der Rückseite des Geräts oder in der Kurzanleitung und folgen Sie dann den Anweisungen auf dem Bildschirm, um die Einrichtung abzuschließen.

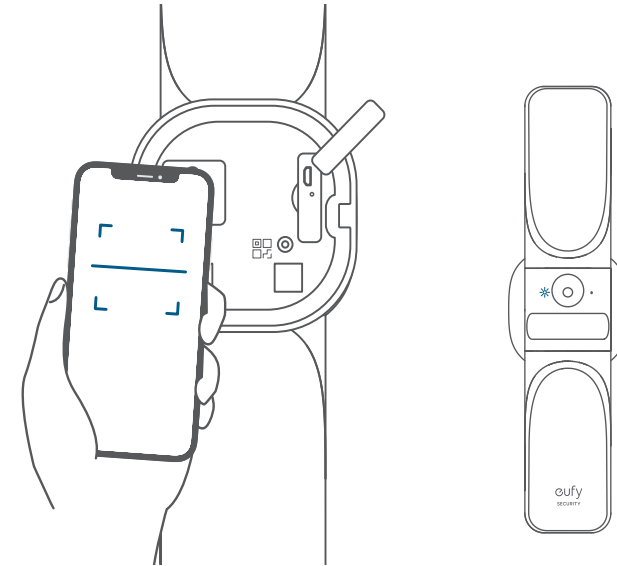

4. Trennen Sie das Gerät von der Stromversorgung, schließen Sie die Abdeckung des USB-Anschlusses und befestigen Sie die Gummistopfen.

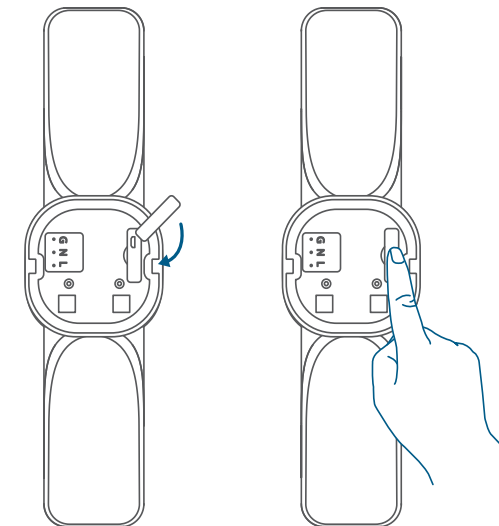

INSTALLATION



Um das Risiko eines Stromschlags, einer Verletzung oder des Todes zu vermeiden, gehen Sie bei Arbeiten mit Elektrizität immer vorsichtig vor. Beauftragen Sie einen professionellen Elektriker, wenn Sie sich bei Arbeiten an der elektrischen Verkabelung nicht sicher fühlen.

1. Schalten Sie die Sicherung in Ihrem Haus aus. Schalten Sie das Licht ein und aus, um zu prüfen, ob der Strom in Ihrer Wohnung ordnungsgemäß abgeschaltet ist.

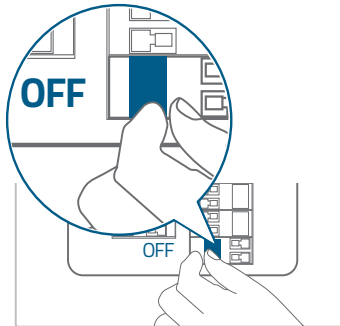

2. Wählen und markieren Sie den Installationsort auf einem ebenen Wandabschnitt.

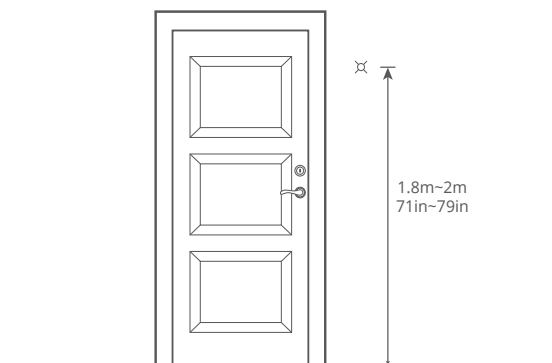

Für eine optimale Bewegungserkennung:

- Stellen Sie sicher, dass das Gerät auf einer ebenen Fläche steht und parallel zur Wand installiert ist. Installieren Sie das Gerät nicht mit einer Neigung nach oben oder nach unten.
- Installieren Sie das Gerät zwischen 1,8 m und 2 m über dem Boden des Bewegungserkennungsbereichs. Installieren Sie das Gerät nicht höher als 2,2 m über dem Boden.

3. Falls eine Halterung von einer früheren Leuchte vorhanden ist, entfernen Sie diese, bevor Sie fortfahren.

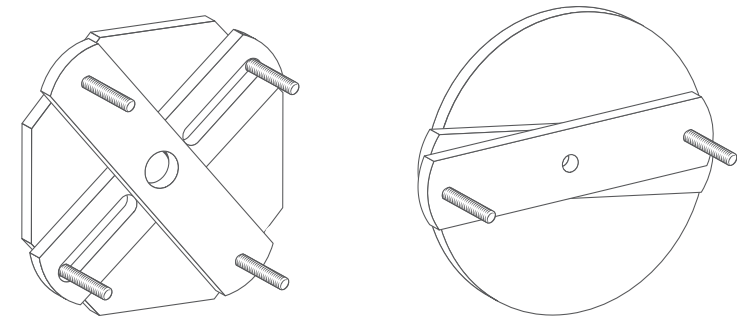

4. Schrauben Sie dann die Halterung an die Wand.

- Bohren Sie bei Holzwänden keine Löcher vor. Befestigen Sie die Montagehalterung mit den mitgelieferten Schrauben an der Wand.
- Bei Wänden aus hartem Material, wie z. B. Stuck, Backstein oder Backstein, bohren Sie Löcher an den gewünschten Stellen vor, setzen Sie die mitgelieferten Dübel ein und befestigen Sie die Halterung mit den mitgelieferten Schrauben an der Wand.

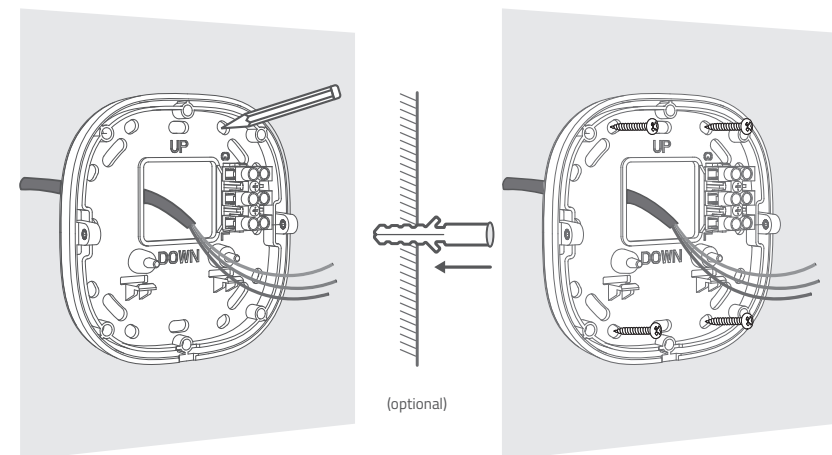

5. So vermeiden Sie Schwierigkeiten bei der Montage des Geräts auf der Montagehalterung:

- Stellen Sie sicher, dass die Kabel nicht zu dick sind.
- Versuchen Sie, die Kabel in einem Winkel von 90° zu biegen.

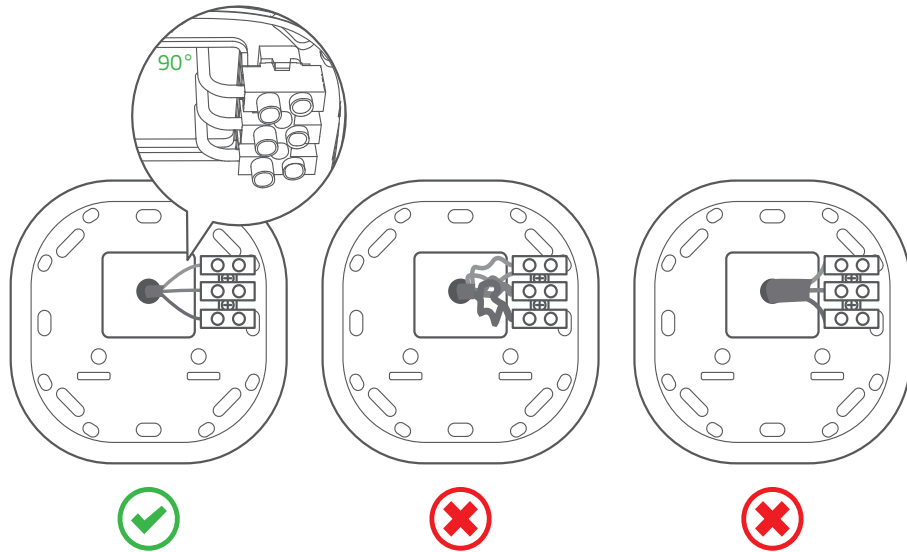

6. Lösen Sie die Kabelschrauben, stecken Sie den Neutralleiter, den Schutzleiter und den stromführenden Leiter in die Verbinder und ziehen Sie dann die Kabelschrauben fest, um die Kabel zu sichern.

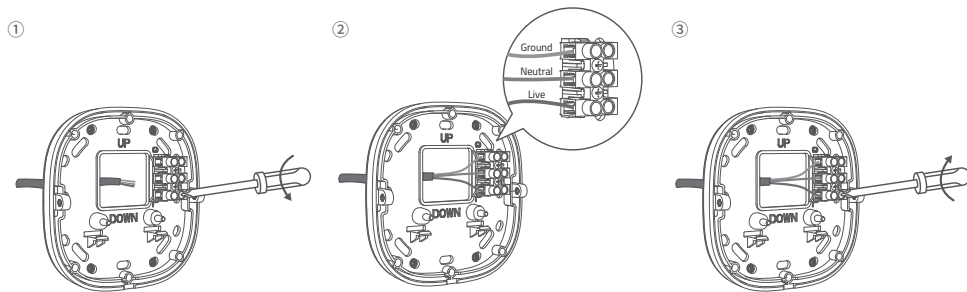

	Nordamerika	Europa
Schutzleiter	Grün/Gelb	Grün/Gelb
Neutralleiter	Weiß	Blau
Stromführender Leiter	Schwarz	Braun

Der Farben der Kabel können je nach Region variieren.

7. Montieren Sie das Gerät auf die Halterung und sichern Sie es mit einer Schraube auf jeder Seite.

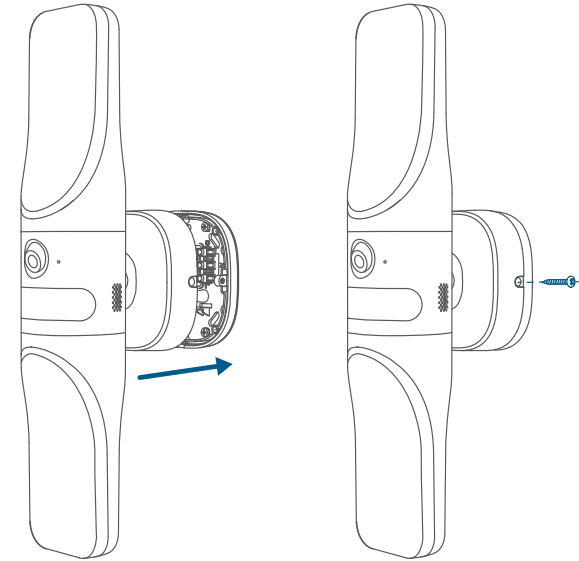

8. Schalten Sie die Sicherung in Ihrem Haus an.

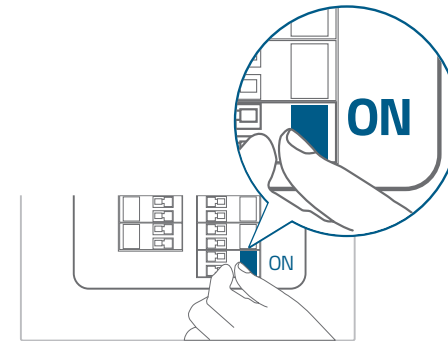

EINSTELLEN DES WINKELS

1. Drehen Sie das Gerät, während Sie den über die eufy Security-App zugänglichen Live-Stream überprüfen, bis Sie die gewünschte Ansicht erhalten.

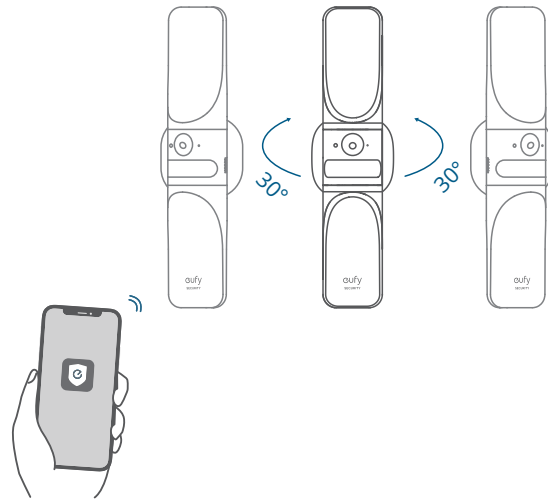

2. Drehen Sie das Licht, um den besten Winkel für die Beleuchtung Ihres Raums zu finden.

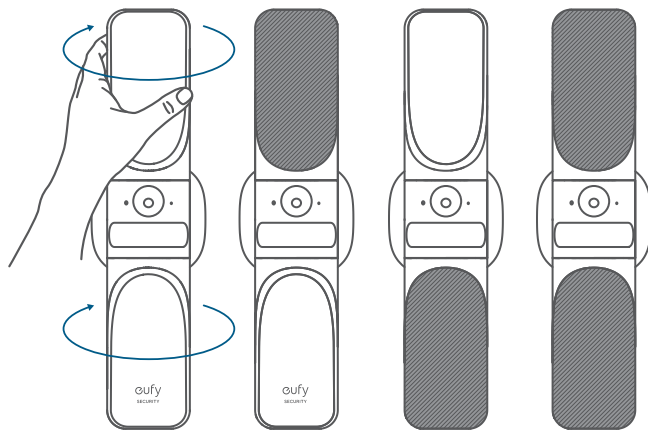

VISTA GENERAL

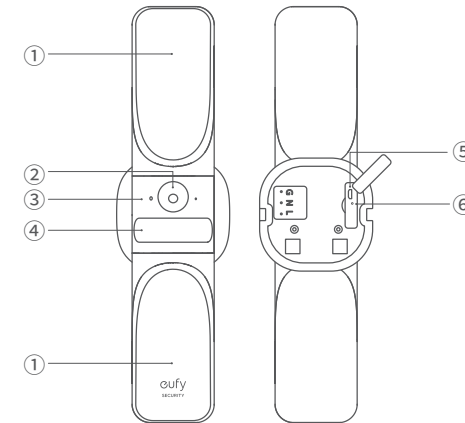

- ① Luz
- ② Objektiv de la cámara
- ③ LED de estado
- ④ Sensor de movimiento
- ⑤ Puerto micro-USB
- ⑥ Orificio de reinicio

Contenido



Cámara con luz de pared S100



Base de montaje

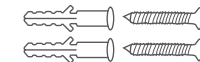

Tornillo para la base



Tornillo de sujeción de la cámara



Cable USB



Guía de inicio rápido

Configuración del sistema

1. Abra la tapa del puerto USB de la parte posterior del dispositivo y conecte el cable de corriente incluido. El LED de estado se iluminará en rojo cuando el dispositivo esté listo para configurarse.

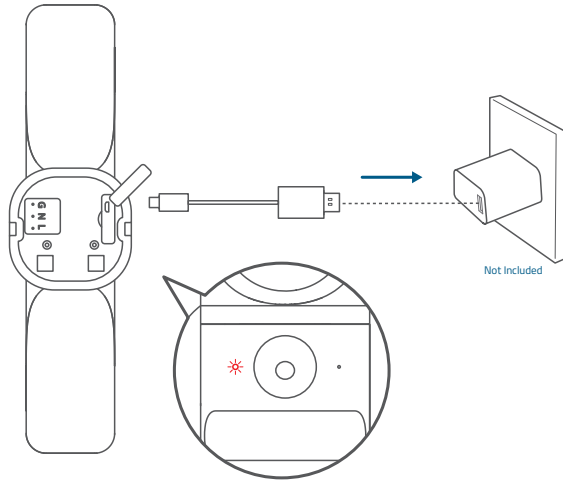

⚠ Las luces principales no responderán mientras el dispositivo esté funcionando a través del puerto USB.

2. Descargue e instale la aplicación eufy Security y cree una cuenta.

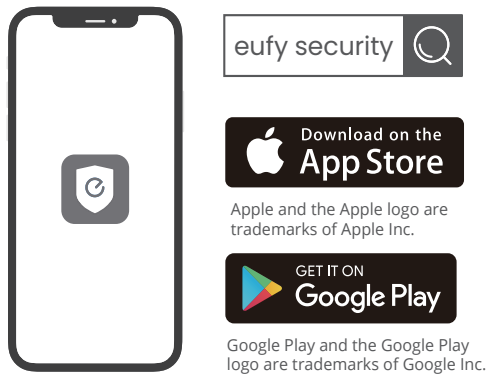

3. Escanee el código QR que está en la parte posterior del dispositivo o la guía de inicio rápido y siga las instrucciones en pantalla para completar la configuración.

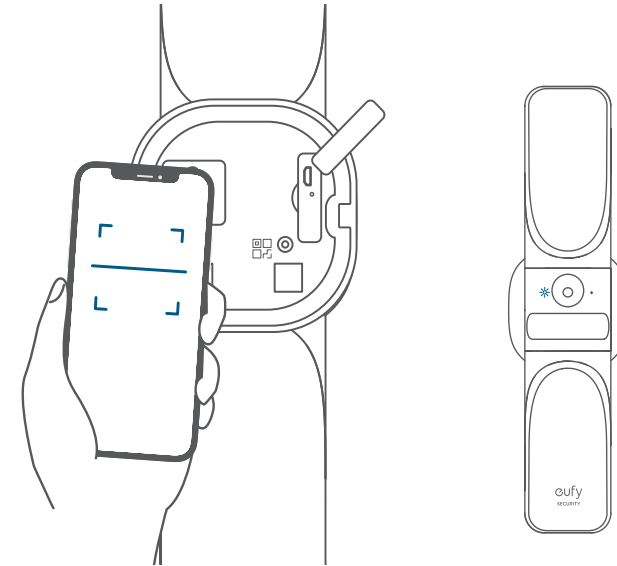

4. Desenchufe el dispositivo de la corriente, cierre la tapa del puerto USB y luego fije bien los tapones de goma.

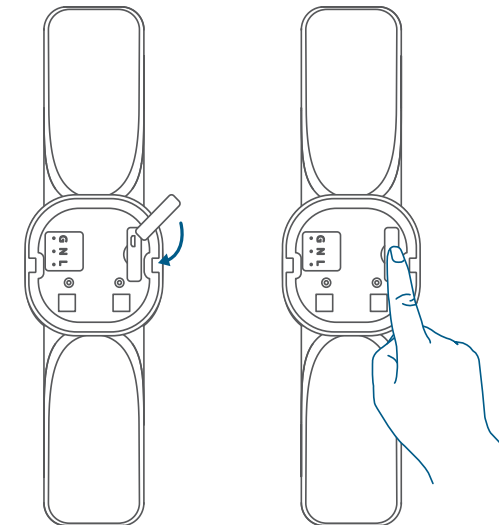

INSTALACIÓN



Para evitar el riesgo de descargas eléctricas, lesiones o incluso muerte, tenga siempre cuidado al trabajar con electricidad. Llame a un electricista profesional si no quiere manipular el cableado eléctrico.

1. Desconecte el diferencial de su casa. Encienda y apague las luces para comprobar que no hay suministro de electricidad en su hogar.

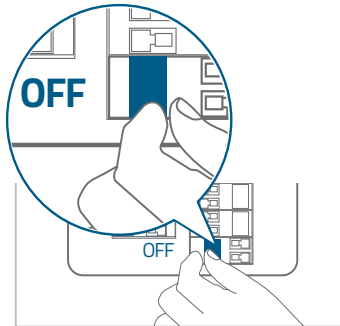

2. Localice y marque la zona de instalación en un área lisa y plana de la pared.

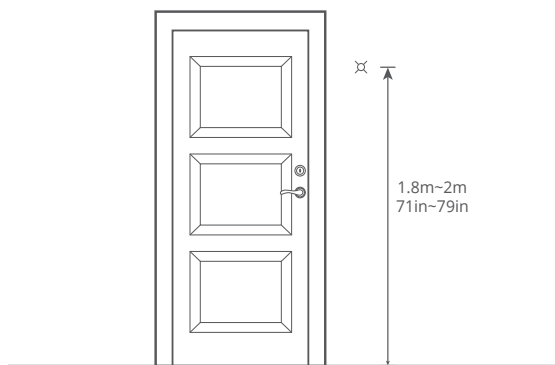

Para que la detección de movimiento funcione de la mejor manera:

- Asegúrese de que el dispositivo esté colocado en una superficie plana y que se monte paralelo a la pared. No instale el dispositivo inclinado hacia arriba o hacia abajo.
- Coloque el dispositivo a una altura de entre 1,8 m (71 pulg.) y 2 m (79 pulg.) sobre el nivel del suelo que haya sobre la zona de detección de movimiento. No monte el dispositivo a más de 2,2 m (87 pulg.) de altura del suelo.

3. Si hay un soporte de una luz ya instalada, retírela antes de continuar.

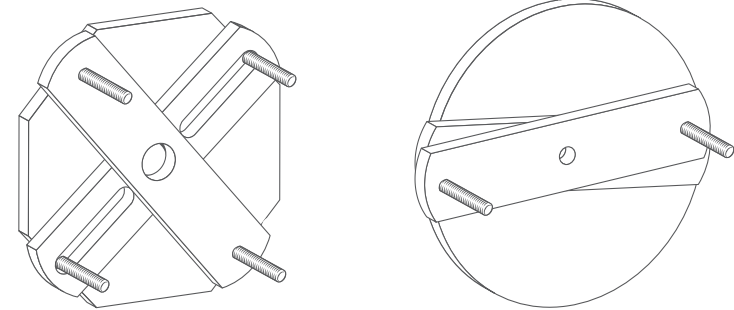

4. Atornille el soporte de montaje a la pared.

- En paredes de madera, no taladre agujeros. Utilice los tornillos incluidos para fijar el soporte de montaje a la pared.
- En paredes hechas de materiales duros, como estuco, ladrillo u hormigón, taladre los agujeros en los puntos correspondientes, introduzca los anclajes incluidos y luego use los tornillos designados para fijar el soporte de montaje a la pared.

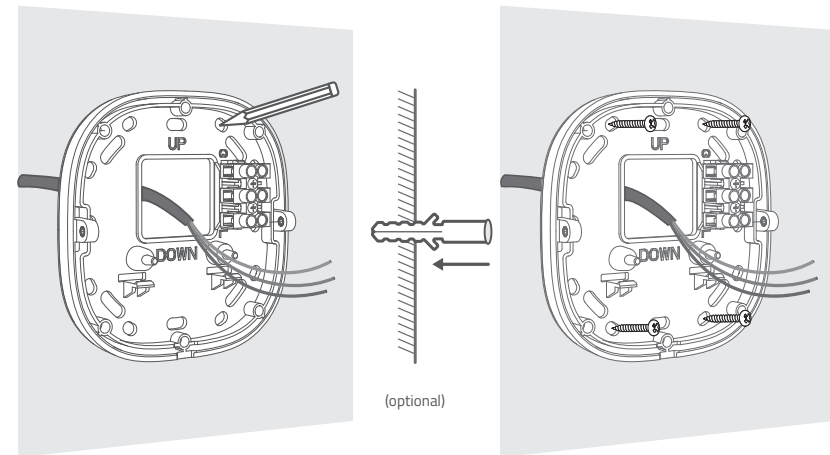

5. Cómo facilitar la instalación del dispositivo en el soporte de montaje:

- Compruebe que los cables no sean demasiado gruesos.
- Intente doblar los cables en un ángulo de 90°.

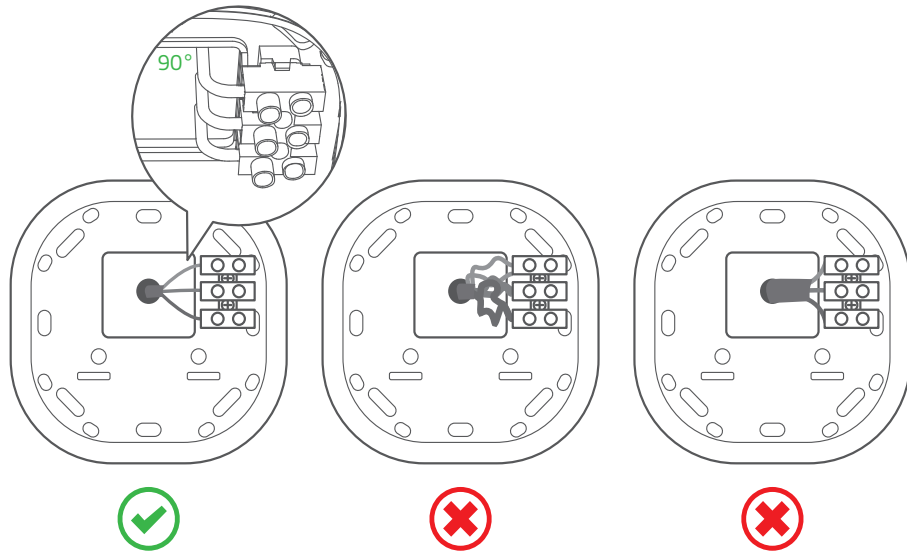

6. Afloje los tornillos para cables, introduzca los cables neutros, de toma de tierra y de corriente en los conectores y luego apriete los tornillos para cables para sujetar bien los cables.

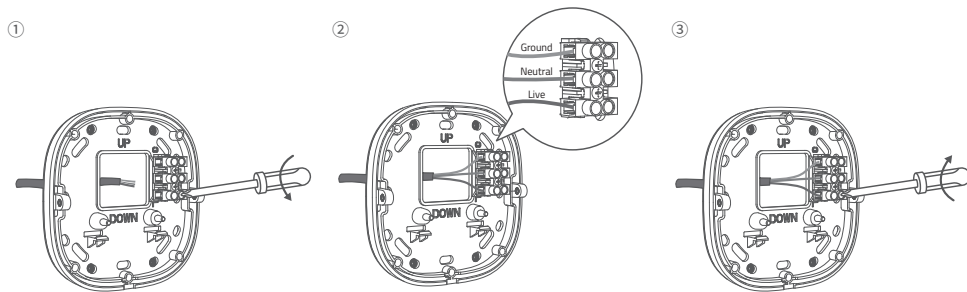

	Norteamérica	Europa
Toma de tierra	Verde / Amarillo	Verde / Amarillo
Neutro	Blanco	Azul
De corriente	Negro	Marrón

Los colores de los cables varían según la región.

7. Coloque el dispositivo en el soporte de montaje y fíjelo con un tornillo en cada lado.

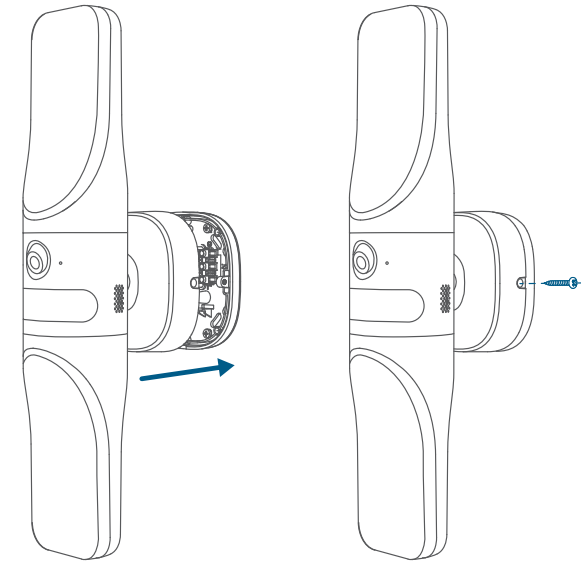

8. Conecte el diferencial de su casa.

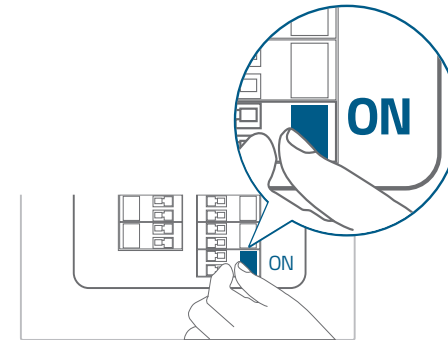

ÁNGULOS DE AJUSTE

1. Gire el dispositivo a la vez que comprueba que sale la imagen en directo en la aplicación eufy Security hasta conseguir el ángulo deseado.

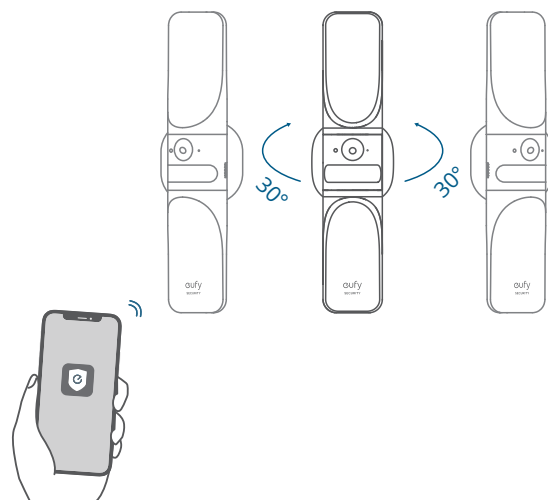

2. Gire la luz para dar con el mejor ángulo para iluminar el espacio.

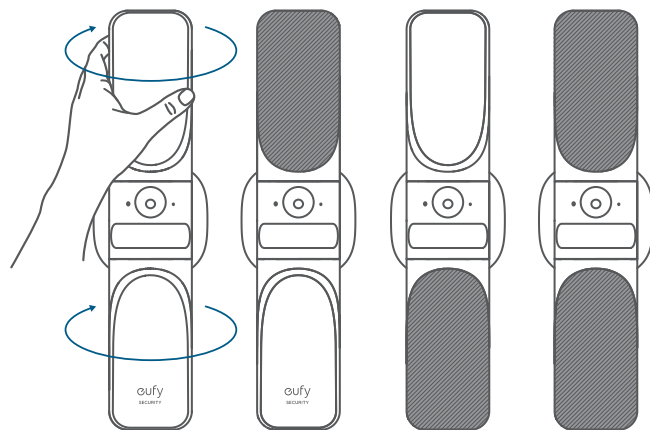

RÉCAPITULATIF

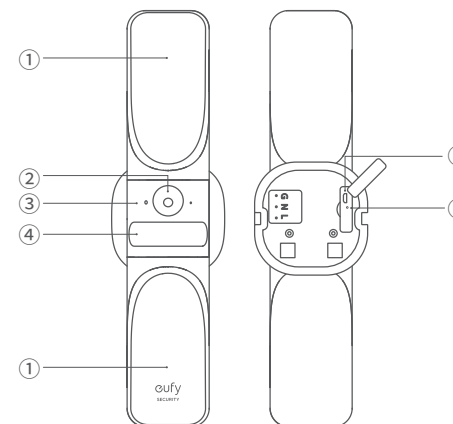

- ① Lumière
- ② Objectif de caméra
- ③ Voyant d'état
- ④ Détecteur de mouvement
- ⑤ Port micro USB
- ⑥ Orifice de réinitialisation

Contenu



S100 Wall Light Cam



Base de montage



Vis de base



Vis de fixation de la caméra



Câble USB



GUIDE DE DÉMARRAGE RAPIDE

Configuration du système

1. Ouvrez le couvercle du port USB à l'arrière de l'appareil, puis connectez-le à l'alimentation avec le câble fourni. Le voyant d'état s'allume en rouge lorsque l'appareil est prêt à être configuré.

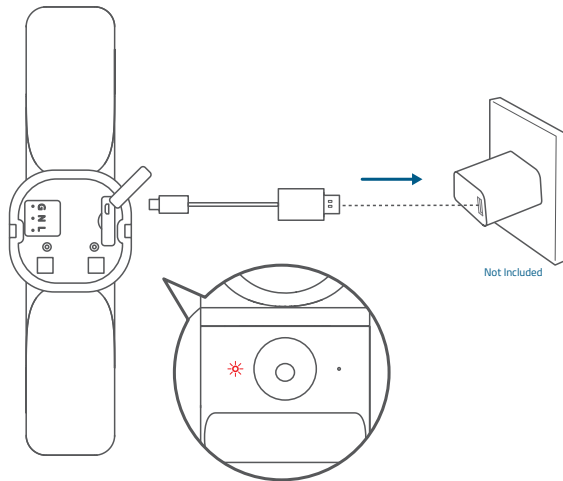

⚠ Les lumières principales ne fonctionnent pas lorsque l'appareil est alimenté par le port USB.

2. Téléchargez et installez l'application eufy Security, puis créez un compte.

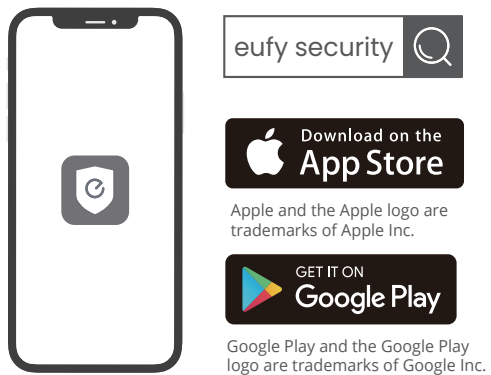

3. Scannez le code QR au dos de l'appareil ou sur le Guide de démarrage rapide, puis suivez les instructions à l'écran pour terminer la configuration.

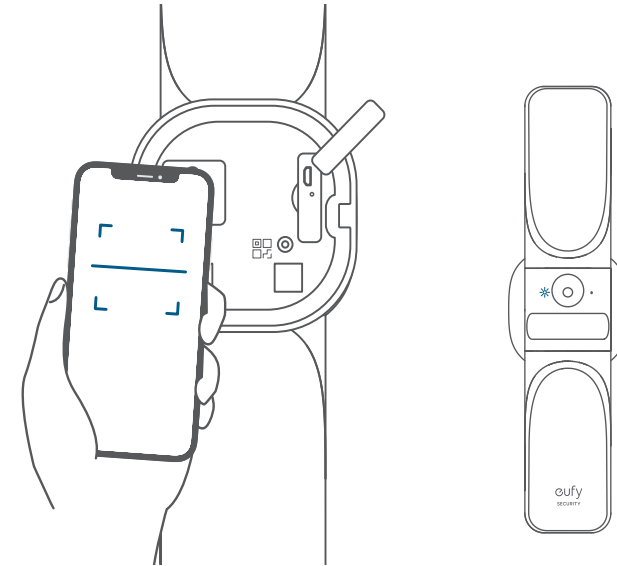

4. Débranchez l'appareil de l'alimentation et fermez le couvercle du port USB, puis fixez les bouchons en caoutchouc.

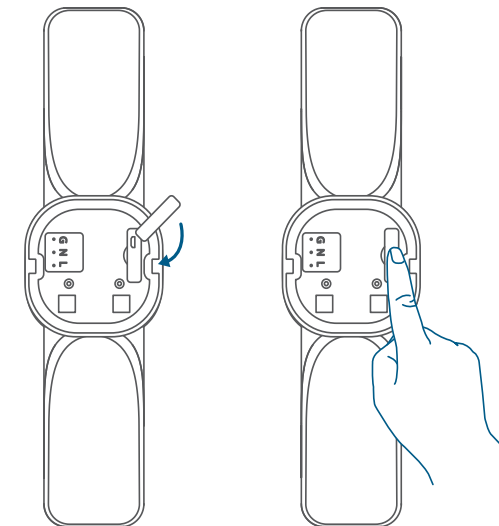

INSTALLATION



Pour éviter tout risque d'électrocution, de blessure ou de mort, soyez toujours prudent lorsque vous travaillez avec l'électricité. Faites appel à un électricien professionnel si vous ne vous sentez pas à l'aise avec le câblage électrique.

1. Coupez le disjoncteur de votre maison. Allumez et éteignez les lumières pour vérifier que l'électricité de votre maison est bien coupée.

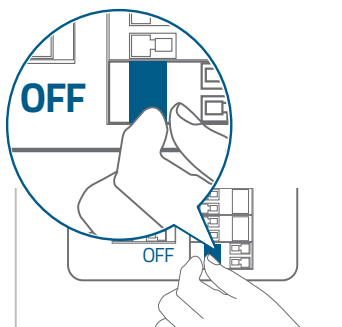

2. Sélectionnez et marquez l'emplacement de l'installation sur une section plate du mur.

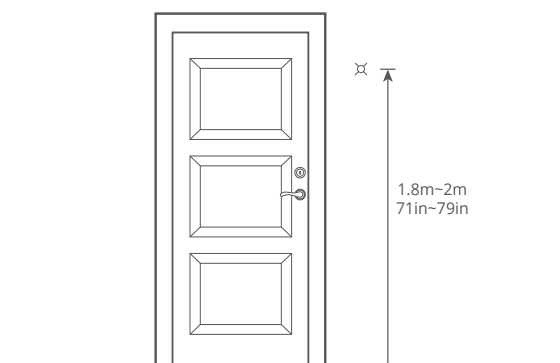

Pour une expérience optimale de la détection de mouvement :

- Assurez-vous que l'appareil est situé sur une surface plane et que l'appareil est installé parallèlement au mur. N'installez pas l'appareil avec une inclinaison vers le haut ou vers le bas.
- Installez l'appareil entre 1,8 m et 2 m au-dessus du niveau du sol de la zone de détection de mouvement. N'installez pas l'appareil à plus de 2,2 m au-dessus du sol.

3. S'il y a une fixation d'une lampe précédente, enlevez-la avant de continuer.

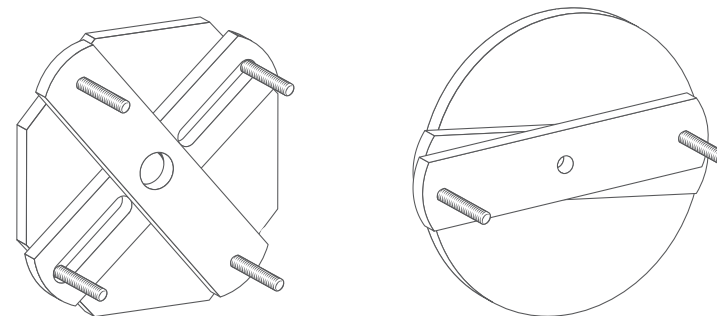

4. Vissez le support de montage sur le mur.

- Sur les murs en bois, ne pré-percez pas de trous. Utilisez les vis fournies pour fixer le support de montage au mur.
- Pour les murs en matériaux durs, tels que le stuc, la brique ou le béton, percez des trous aux endroits requis, insérez les ancrages fournis, puis utilisez les vis fournies pour fixer le support de montage au mur.

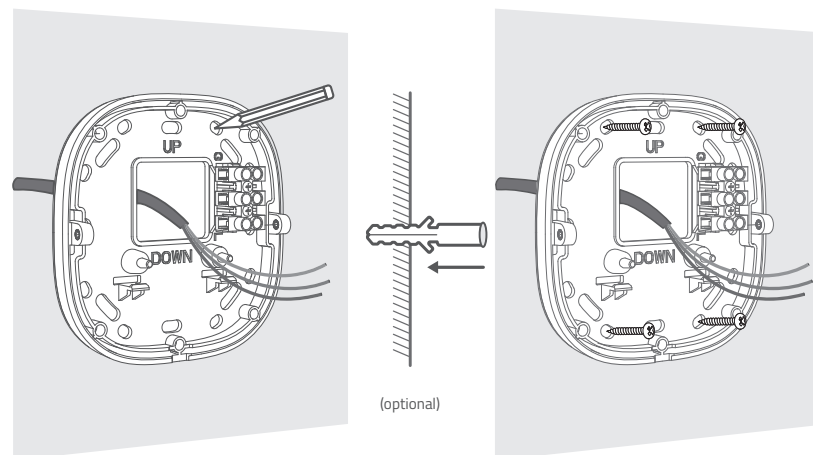

5. Pour éviter toute difficulté lors du montage de l'appareil sur le support de montage :

- Assurez-vous que les fils ne sont pas trop épais.
- Essayez de plier les fils à un angle de 90°.

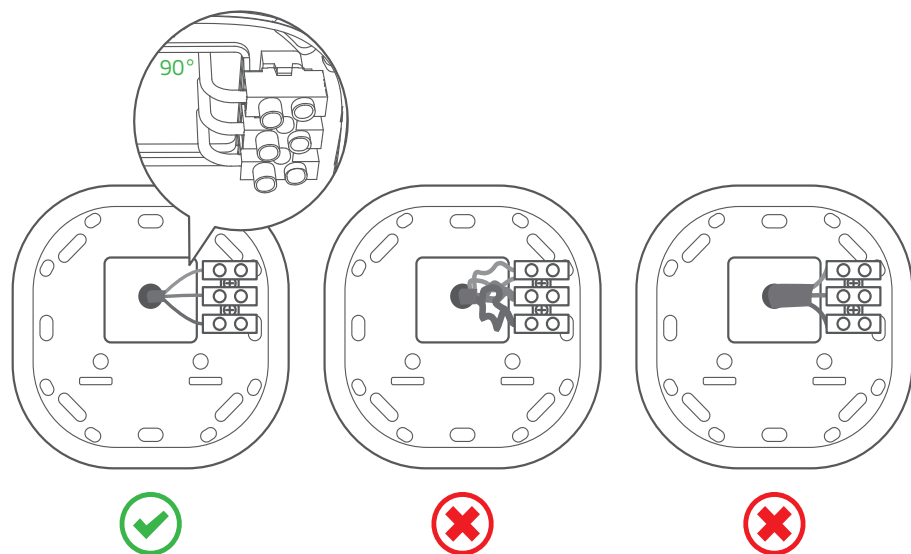

6. Desserrez les vis, insérez les fils neutre, de terre et sous tension dans les connecteurs, puis serrez les vis pour bien fixer les fils.

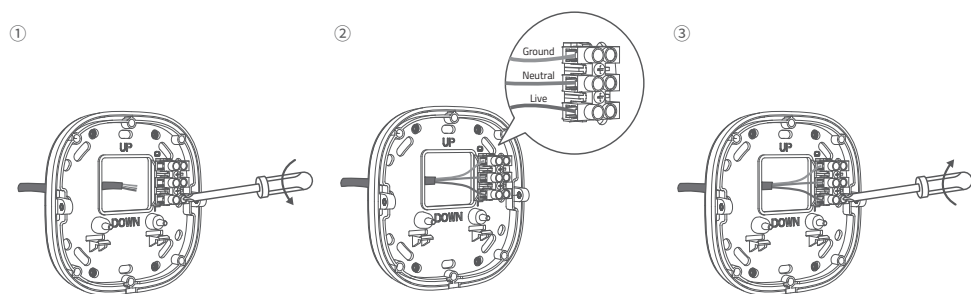

	Amérique du Nord	Europe
Terre	Vert jaune	Vert jaune
Neutre	Blanc	Bleue
Phase	Noir	Marron

 Les couleurs des fils varient selon la région.

7. Montez l'appareil sur le support de montage, puis fixez-le avec une vis de chaque côté.

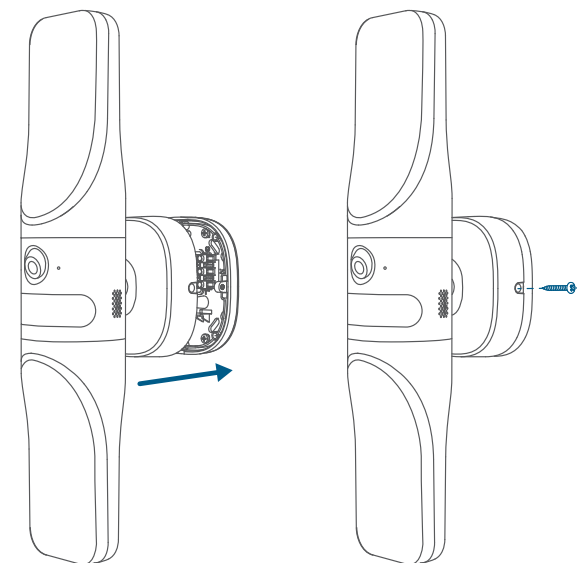

8. Allumez le disjoncteur de votre maison.

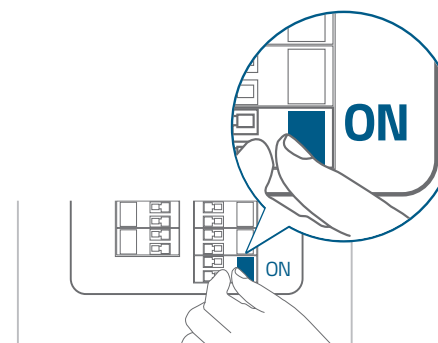

RÉGLAGE DES ANGLES

1. Tournez l'appareil tout en vérifiant le flux en direct depuis l'application eufy Security jusqu'à ce que vous obteniez la vue souhaitée.

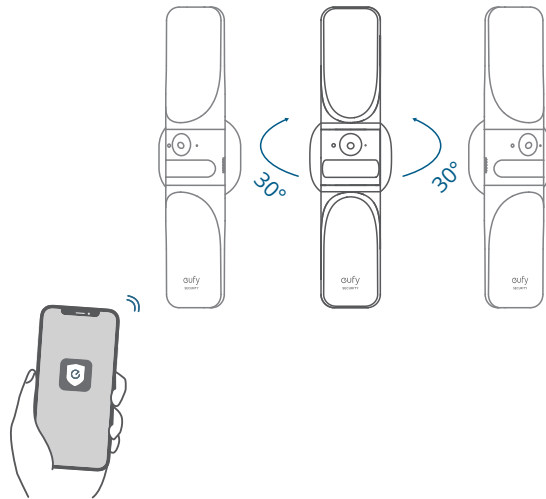

2. Tournez la lumière pour trouver le meilleur angle pour éclairer votre espace.

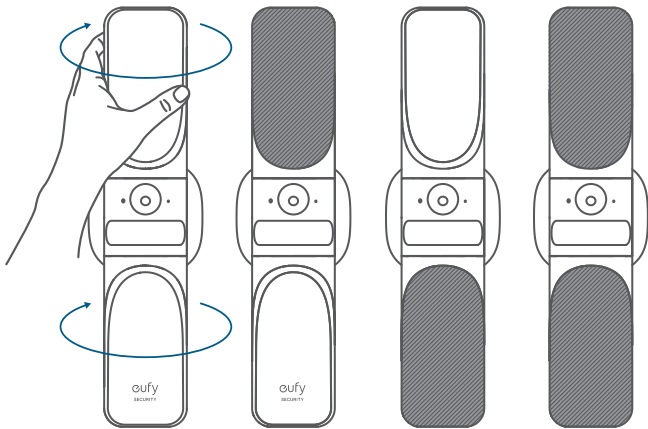

DESCRIZIONE DEL PRODOTTO

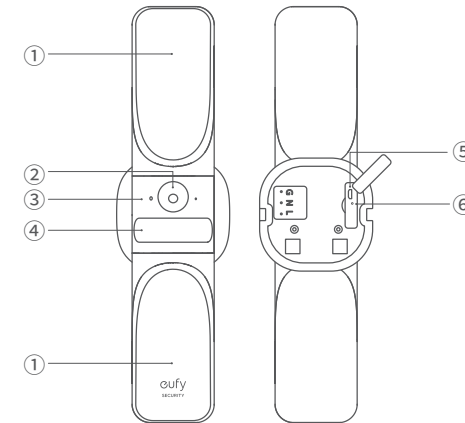

- ① Luce
- ② Obiettivo della telecamera
- ③ LED di stato
- ④ Sensore di movimento
- ⑤ Porta micro USB
- ⑥ Foro di ripristino

CONTENUTO DELLA CONFEZIONE



S100 Telecamera e luce da parete



Base di montaggio

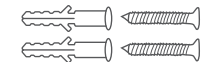

Vite di base



Vite di fissaggio della telecamera



Cavo USB



Guida rapida

Configurazione del sistema

1. Aprire il coperchio della porta USB sul retro del dispositivo, quindi collegarlo all'alimentazione con il cavo in dotazione. Quando il dispositivo è pronto per la configurazione, il LED di stato è rosso.

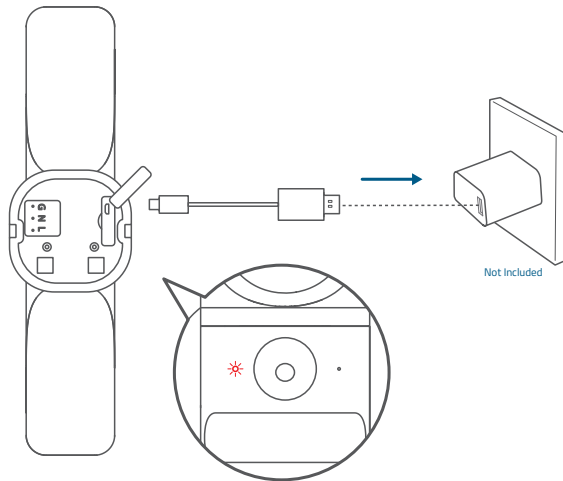

⚠ Le luci principali non funzioneranno quando il dispositivo è alimentato tramite la porta USB.

2. Scaricare e installare l'app eufy Security e configurare un account.

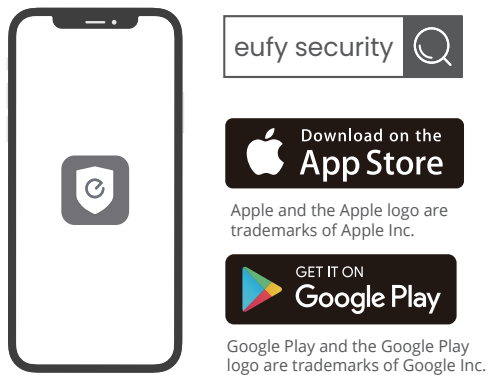

3. Scansionare il codice QR sul retro del dispositivo o della Guida introduttiva, quindi seguire le istruzioni sullo schermo per completare la configurazione.

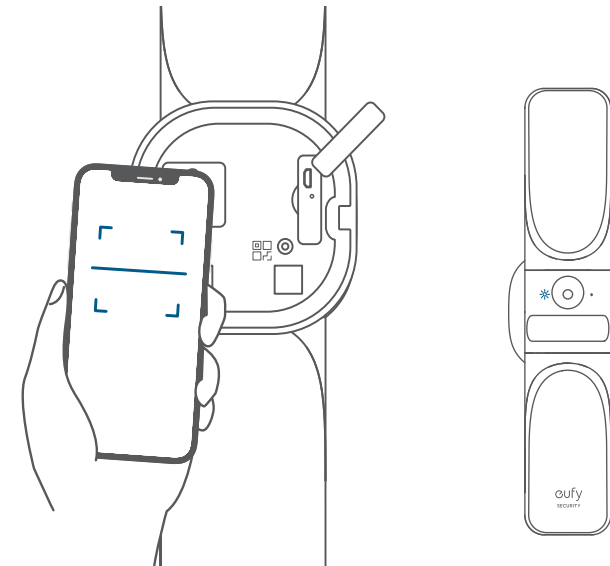

4. Scollegare il dispositivo dall'alimentazione e chiudere il coperchio della porta USB, quindi fissare i tappi in gomma.

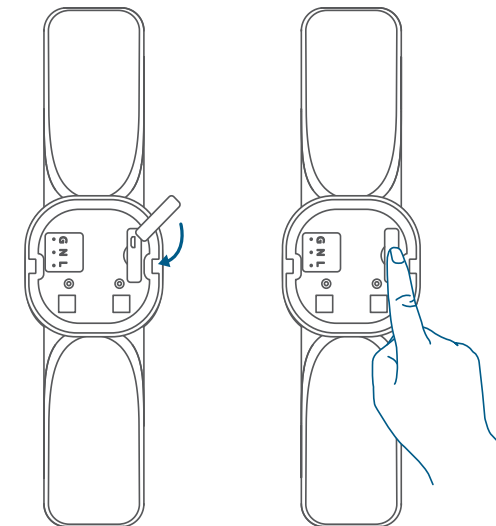

INSTALLAZIONE



Per evitare il rischio di scosse elettriche, lesioni o morte, prestare sempre attenzione quando si lavora con l'elettricità. Assumere un elettricista professionista se si è a disagio nel lavorare con i cavi elettrici.

1. Spegnerne l'interruttore automatico dell'abitazione. Accendere e spegnere le luci per controllare che l'elettricità nell'abitazione sia effettivamente spenta.

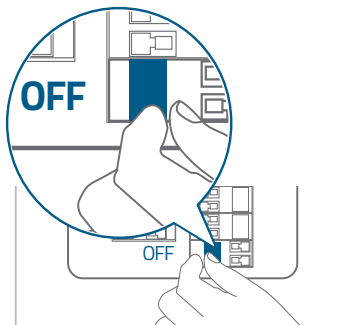

2. Selezionare e contrassegnare la posizione di installazione su una sezione piana del muro.

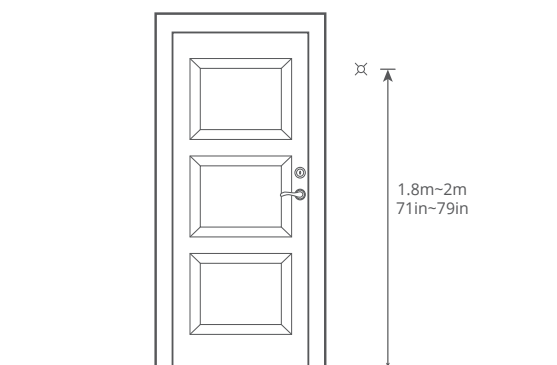

Per la migliore esperienza di rilevamento del movimento:

- Assicurarsi che il dispositivo sia posizionato su una superficie piana e che sia installato parallelamente alla parete. Non installare il dispositivo con un'inclinazione verso l'alto o verso il basso.
- Installare il dispositivo a una distanza compresa tra 1,8 m e 2 m dal suolo dell'area di rilevamento del movimento. Non installare il dispositivo a più di 2,2 m dal suolo.

3. Se è presente la montatura di una luce precedente, rimuoverla prima di continuare.

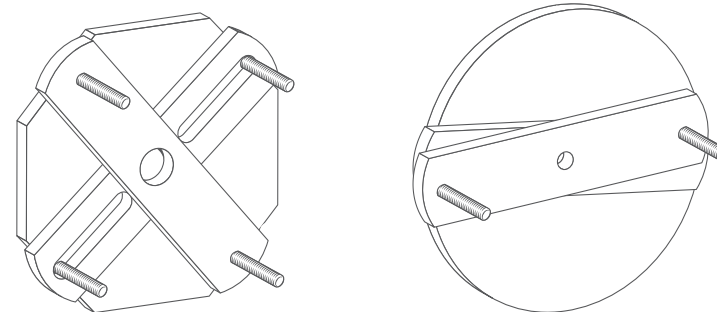

4. Avvitare la staffa di montaggio alla parete.

- Su pareti in legno non praticare fori. Utilizzare le viti in dotazione per fissare la staffa di montaggio alla parete.
- Per pareti in materiali duri, come stucco, mattoni o cemento, eseguire i fori nei punti richiesti, inserire i tasselli in dotazione, quindi utilizzare le viti in dotazione per fissare la staffa di montaggio alla parete.

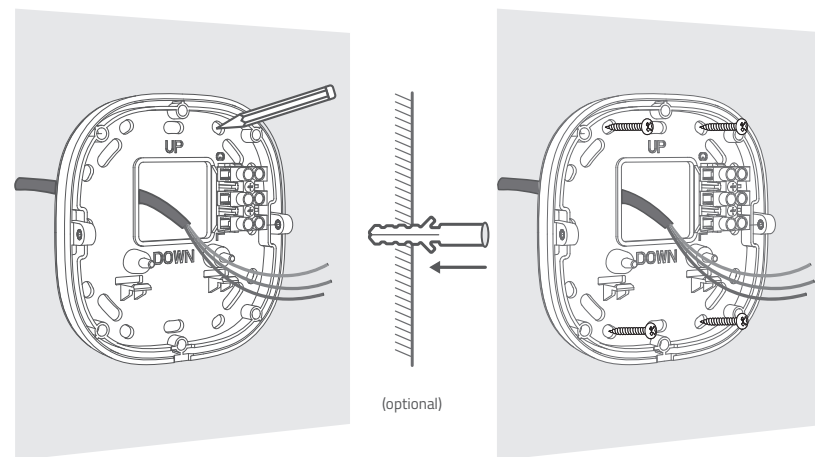

5. Per evitare difficoltà durante il montaggio del dispositivo sulla staffa di montaggio:

- Accertarsi che i cavi non siano troppo spessi.
- Provare a piegare i cavi a un angolo di 90°.

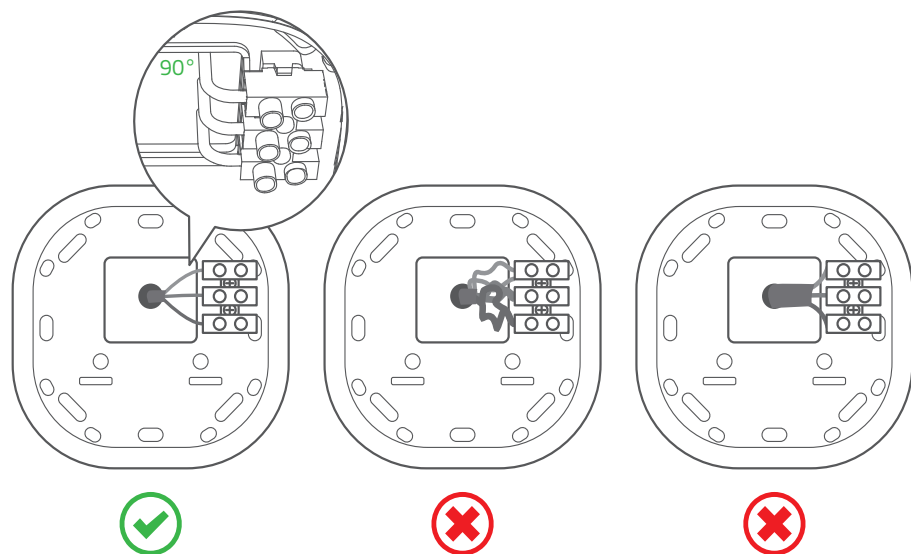

6. Allentare le viti dei cavi, inserire i cavi neutro, di messa a terra e sotto tensione nei connettori, quindi stringere le viti dei cavi per fissarli completamente.

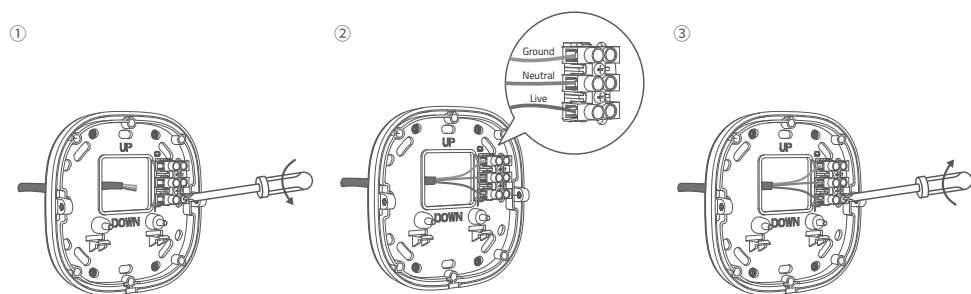

	Nord America	Europa
Messa a terra	Verde/giallo	Verde/giallo
Neutro	Bianco	Blu
Sotto tensione	Nero	Marrone



I colori dei cavi variano a seconda dell'area geografica.

7. Montare il dispositivo sulla staffa di montaggio, quindi fissarlo con una vite su ciascun lato.

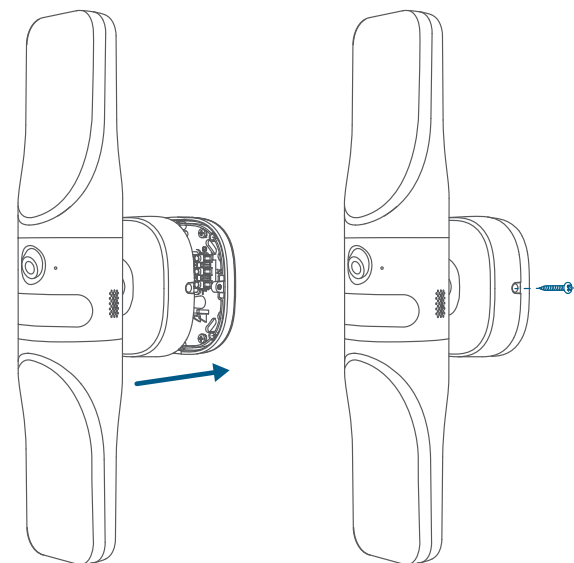

8. Accendere l'interruttore automatico dell'abitazione.

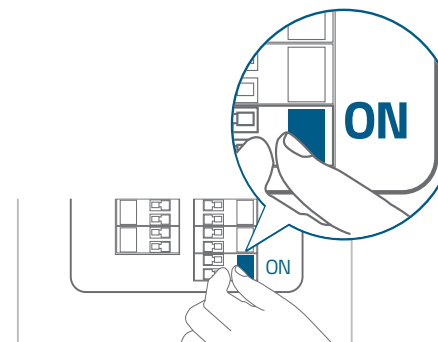

REGOLAZIONE DEGLI ANGOLI

1. Ruotare il dispositivo mentre si controlla la riproduzione in diretta streaming dall'app eufy Security finché non si ottiene la visualizzazione desiderata.

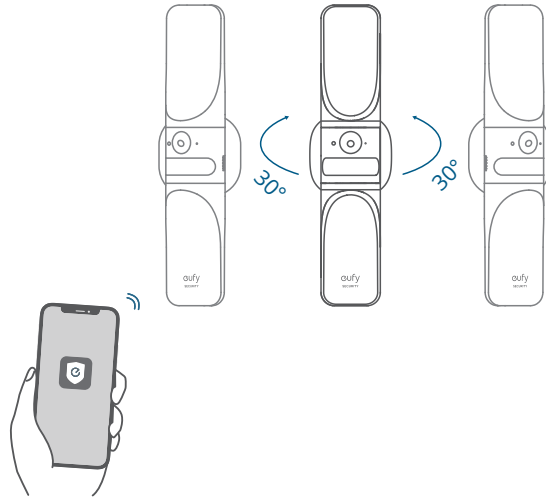

2. Ruotare la luce per trovare l'angolazione migliore per illuminare lo spazio.

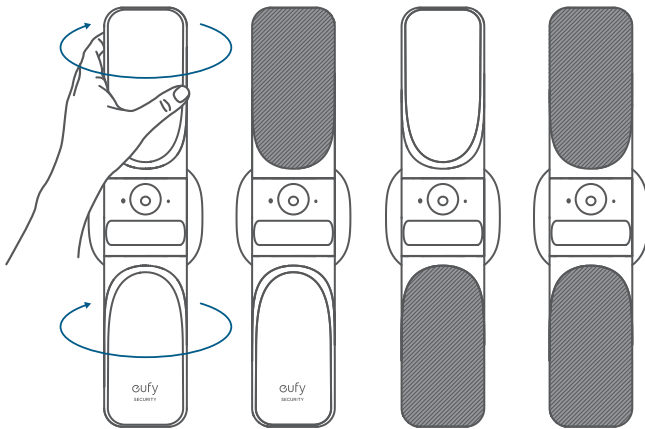

IN EEN OOGOPSLAG

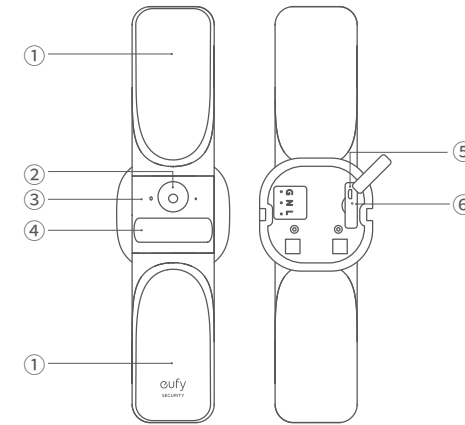

- ① Lamp
- ② Cameralens
- ③ Statusled
- ④ Bewegingssensor
- ⑤ Micro-USB-poort
- ⑥ Resetgaatje

WAT ZIT ER IN DE DOOS?



S100 Wall Light Cam



Montagevoet

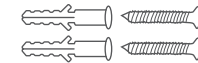

Bevestigingsschroef montagevoet



Bevestigingsschroef camera



USB-kabel



Snelstartgids

Het systeem instellen

1. Open het klepje van de USB-poort achterop het apparaat en sluit de meegeleverde kabel aan op de USB-poort en de voeding. Als het apparaat kan worden ingesteld, brandt de indicatielamp rood.

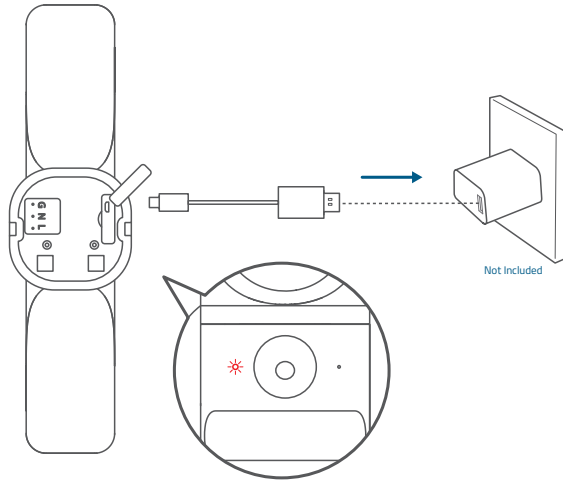

⚠ De hoofdlampen werken niet als het apparaat via de USB-poort van stroom wordt voorzien.

2. Download en installeer de eufy Security-app en stel een account in.

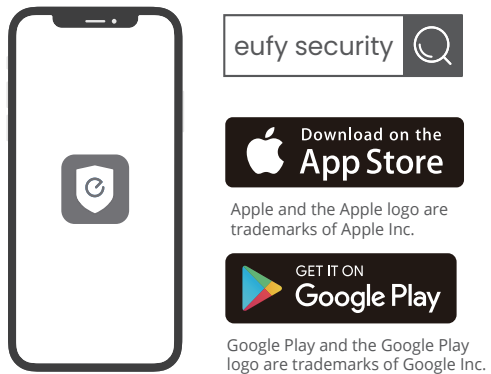

3. Scan de QR-code achterop het apparaat of de beknopte handleiding en volg de instructies op het scherm om het instellen te voltooien.

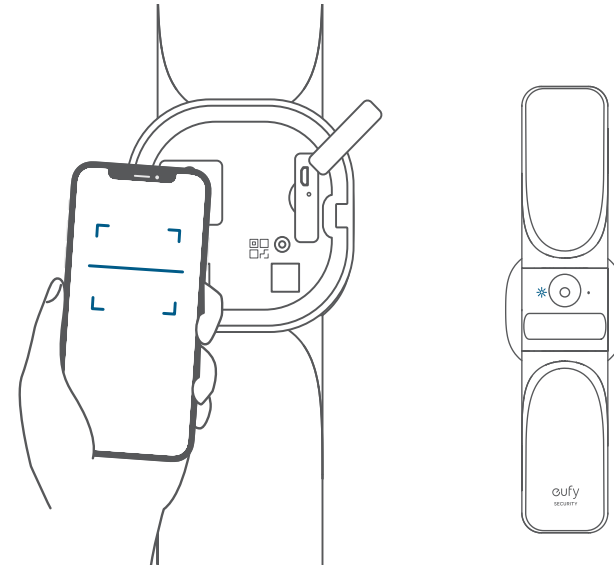

4. Koppel het apparaat los van de voeding en sluit het klepje van de USB-poort en de rubberen dopjes.

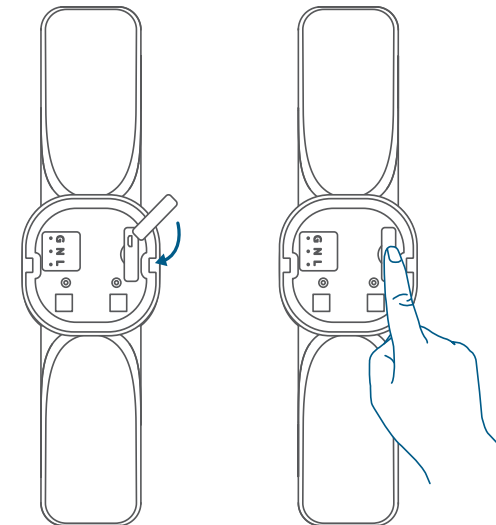

MONTAGE



Wees altijd voorzichtig met elektra om schokken, letsel of overlijden te voorkomen. Schakel een professionele elektricien in als u niet bekend bent met het werken met elektrische bedrading.

1. Onderbreek de stroomvoorziening van uw huis. Doe het licht aan en uit om te controleren of de elektriciteit echt is uitgeschakeld.

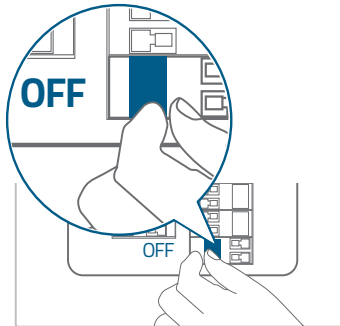

2. Kies een vlakke plek op de muur om de lamp te monteren en markeer de plek.

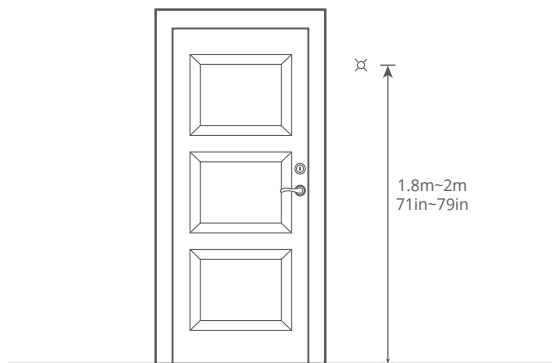

Om de bewegingsdetectie zo goed mogelijk te laten werken:

- Zorgt u dat het apparaat op een vlakke ondergrond en parallel aan de muur wordt gemonteerd. Plaats het apparaat niet omhoog of omlaag gekanteld.
- Monteert u het apparaat tussen 1,8 en 2 meter boven de grond waarop u bewegingen wilt detecteren. Monteer het apparaat niet hoger dan 2,2 meter boven de grond.

3. Als er nog een beugel van een eerdere lamp aanwezig is, verwijdert u die eerst.

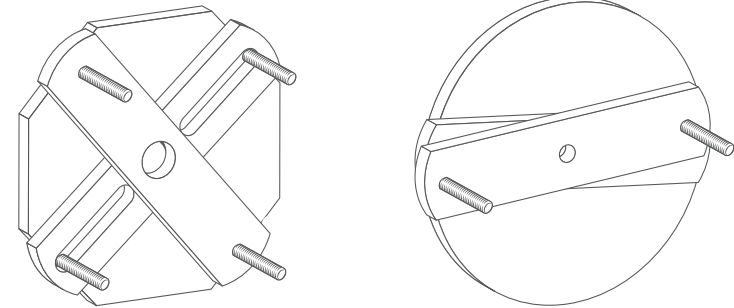

4. Schroef de montagevoet op de muur.

- In een houten ondergrond hoeft u niet voor te boren. Gebruik de meegeleverde schroeven om de montagevoet aan de muur te bevestigen.
- In harde ondergronden, zoals stucwerk, baksteen of beton, boort u op de vereiste locaties gaten voor, plaatst u de meegeleverde pluggen en bevestigt u vervolgens de montagevoet met de meegeleverde schroeven.

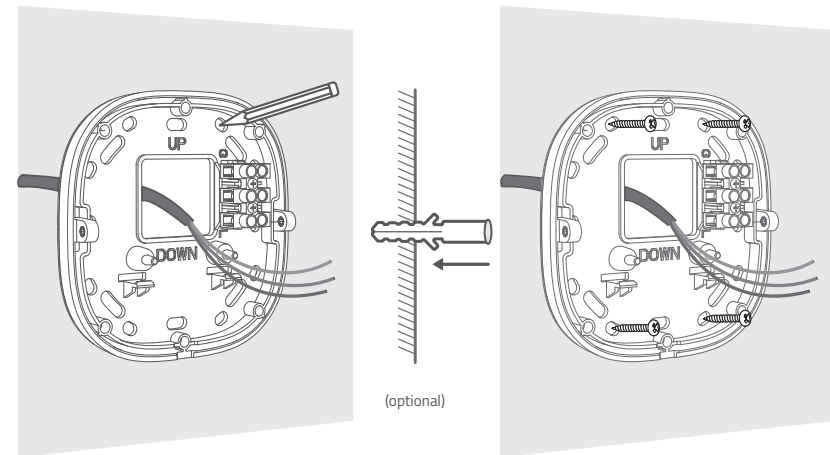

5. Om problemen bij het monteren van het apparaat op de montagebeugel te voorkomen:

- Moet u zorgen dat de draden niet te dik zijn.
- Kunt u proberen om de draden in een hoek van 90° te buigen.

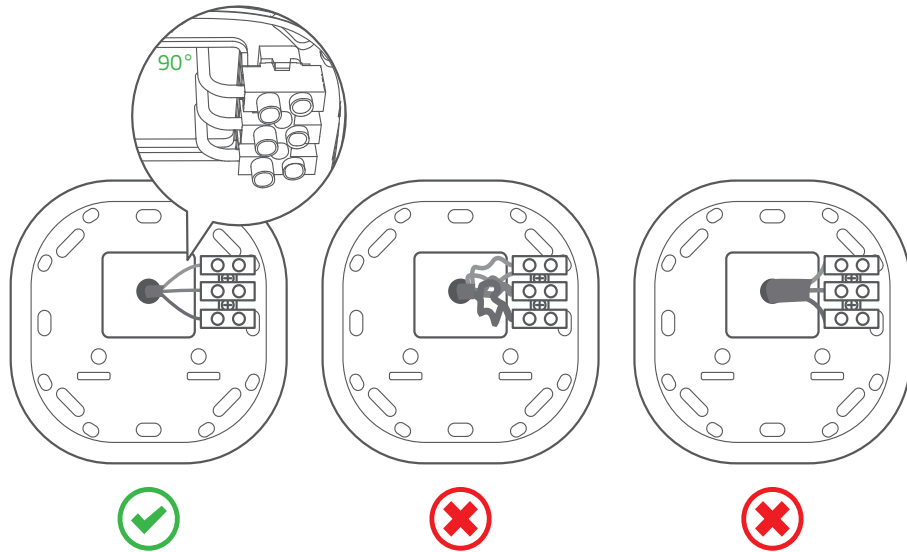

6. Draai de schroeven van de draadklemmen los, steek de fase-, nul- en aardedraad in de klemmen en draai de schroeven weer aan, zodat de draden stevig vastzitten.

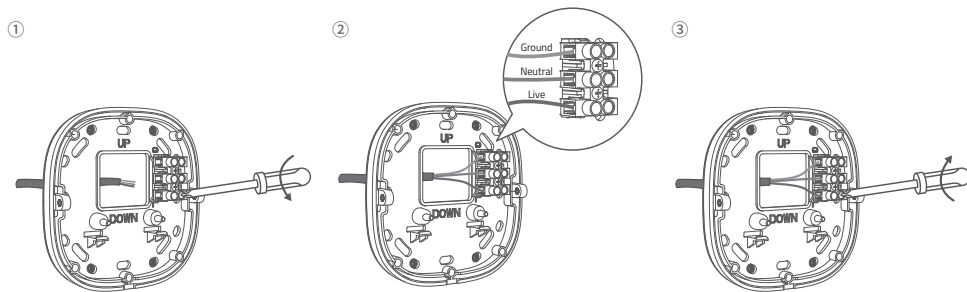

	Noord-Amerika	Europa
Aarde	Groen-geel	Groen-geel
Nul	Wit	Blauw
Fase	Zwart	Bruin

 De kleuren van de draden verschillen per regio.

7. Plaats het apparaat op de montagevoet en zet het vast met een schroef aan elke kant.

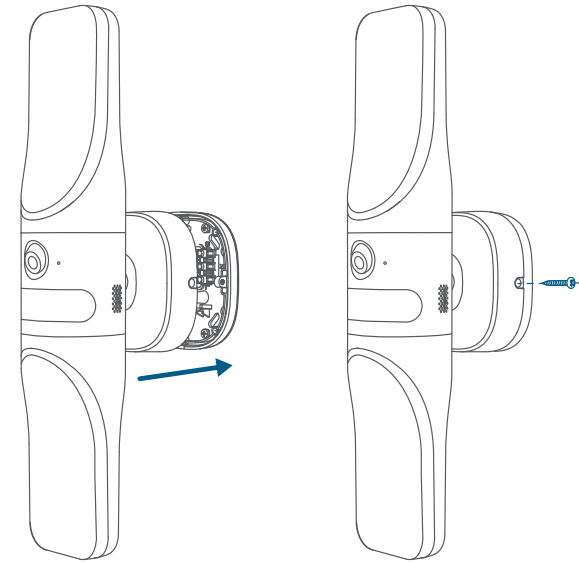

8. Herstel de stroomvoorziening van uw huis.

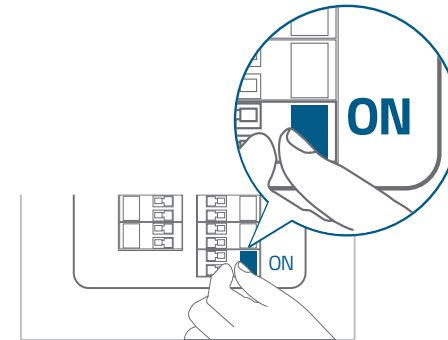

DE HOEK AANPASSEN

1. Draai het apparaat terwijl u de livestream van de eufy Security-app bekijkt, tot u het gewenste beeld hebt.

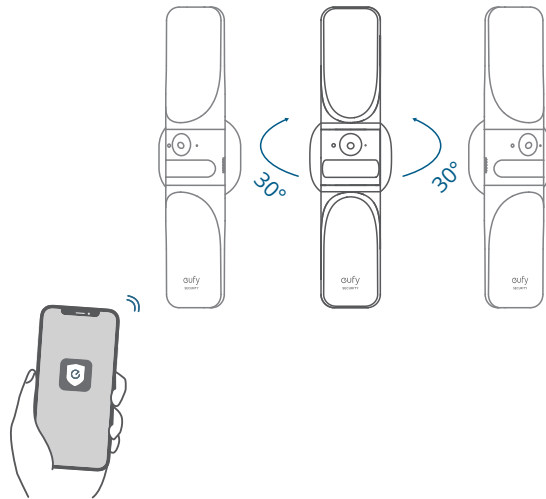

2. Draai het licht om de juiste hoek voor het verlichten van uw ruimte te vinden.

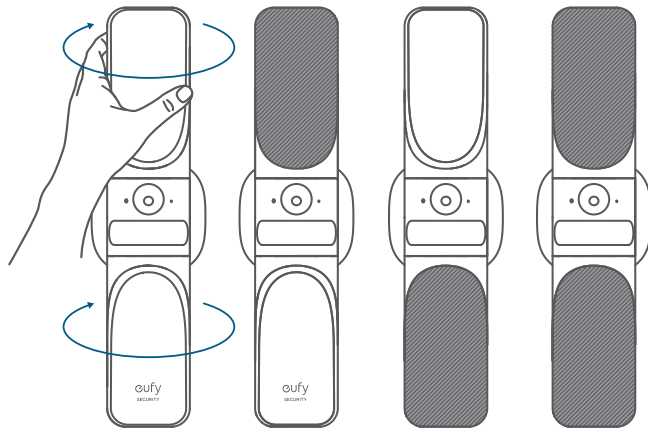

VISTA GERAL

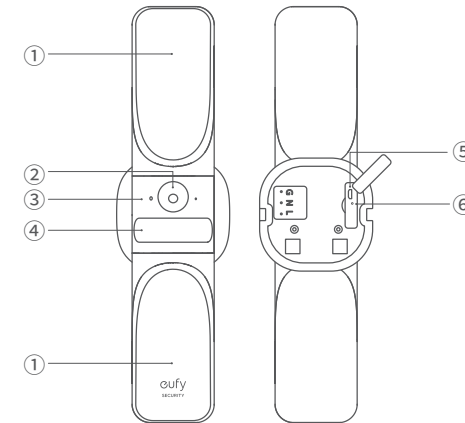

- ① Luz
- ② Lente da câmara
- ③ LED de estado
- ④ Sensor de movimento
- ⑤ Porta micro-USB
- ⑥ Orifício de reposição

INCLUÍDO



Câmara com luz de parede S100



Base de montagem

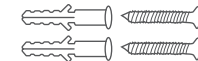

Parafuso da base



Parafuso de fixação da câmara



Cabo USB



GUIA DE INÍCIO RÁPIDO

Configurar o sistema

1. Abra a tampa da porta USB na parte posterior do dispositivo e depois ligue à corrente com o cabo fornecido. O LED de estado fica vermelho quando o dispositivo estiver pronto para ser configurado.

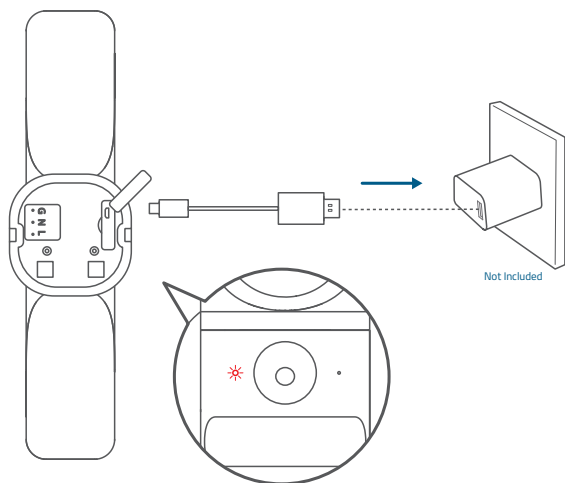

⚠ As luzes principais não funcionam enquanto o dispositivo receber energia através da porta USB.

2. Transfira e instale a aplicação eufy Security e depois configure uma conta.



3. Leia o código QR existente na parte posterior do dispositivo ou Guia de início rápido e siga as instruções apresentadas no ecrã para concluir a configuração.

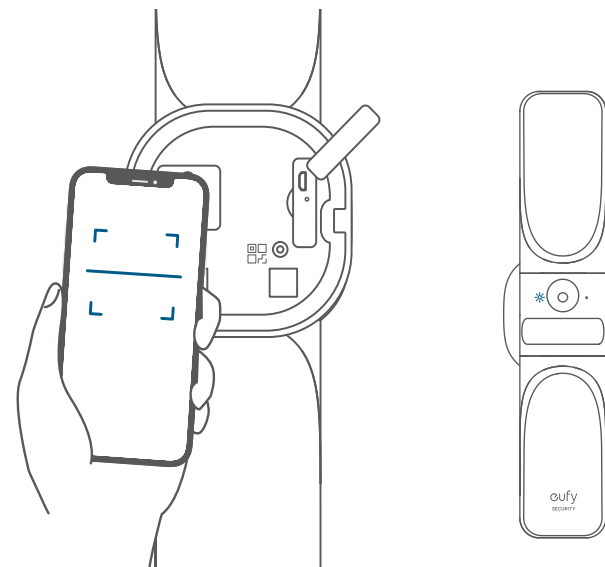

4. Desligue o dispositivo da corrente, feche a tampa da porta USB e depois fixe as tampas de borracha.

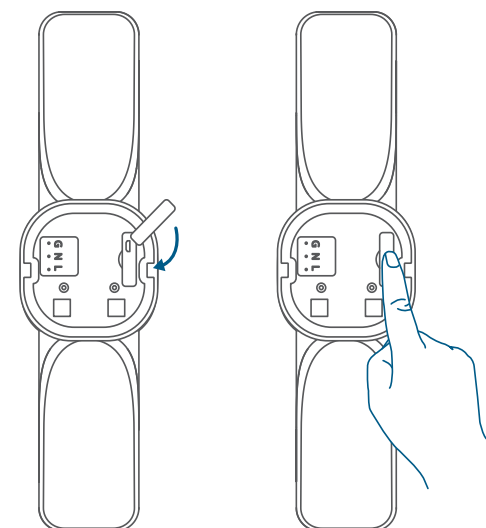

INSTALAÇÃO



Para evitar o risco de choque, ferimentos ou morte, tenha sempre cuidado quando trabalhar com eletricidade. Contrate um electricista profissional se não se sentir confortável em trabalhar com fios elétricos.

1. Desligue o disjuntor de sua casa. Ligue e desligue as luzes para verificar se cortou o fornecimento de eletricidade em sua casa.

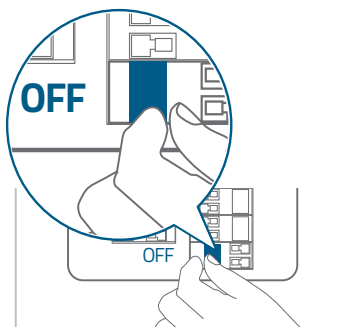

2. Selecione e marque o local de instalação numa secção lisa da parede.

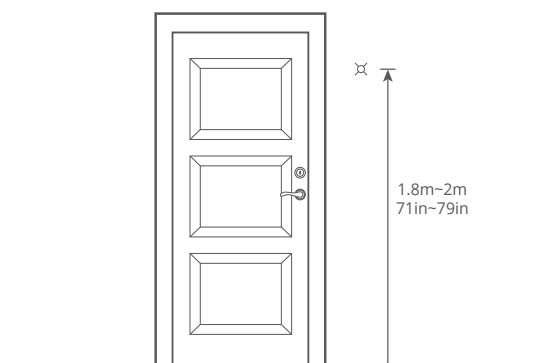

3. Se existir uma instalação anterior de um equipamento de luz, remova-a antes de continuar.

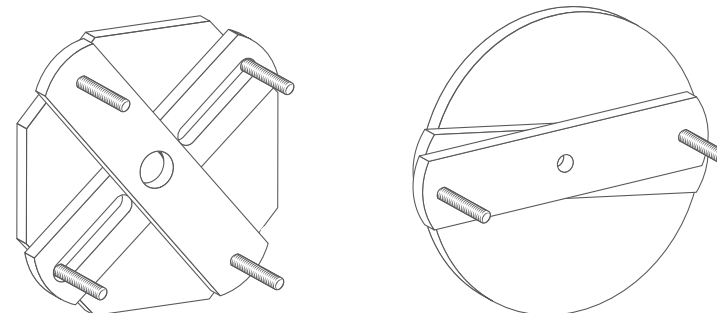

4. A seguir, aparafuse o suporte de montagem à parede.

- Em paredes de madeira, não pré-perfure os orifícios. Utilize os parafusos fornecidos para fixar o suporte de instalação à parede.
- Para paredes feitas de materiais duros, como estuque, tijolo ou cimento, pré-perfure os orifícios nas posições necessárias, insira as buchas fornecidas e depois utilize os parafusos fornecidos para fixar o suporte de montagem à parede.

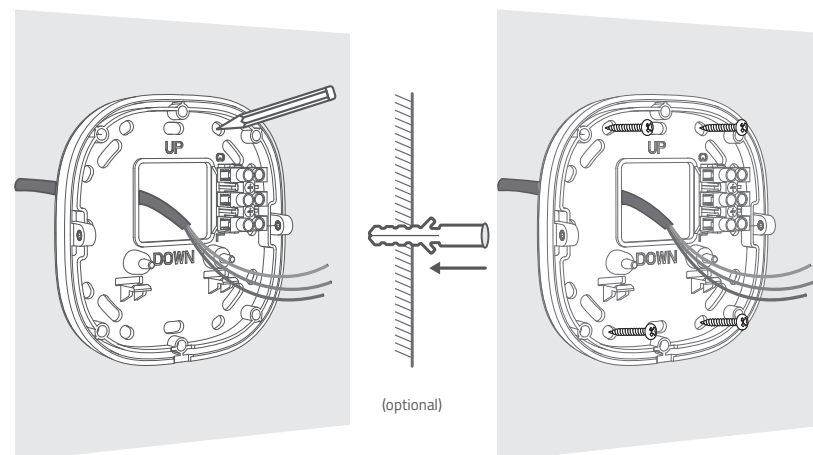

Para usufruir da melhor experiência de deteção de movimento:

- Certifique-se de que o dispositivo está posicionado numa superfície lisa e é instalado paralelamente à parede. Não instale o dispositivo com uma inclinação ascendente ou descendente.
- Instale o dispositivo entre 1,8 m e 2 m acima do nível do solo da área de deteção de movimento. Não instale o dispositivo a mais de 2,2 m acima do solo.

5. Para poder instalar facilmente o dispositivo no suporte de instalação:

- Certifique-se de que os fios não são demasiado grossos.
- Tente dobrar os fios num ângulo de 90°.

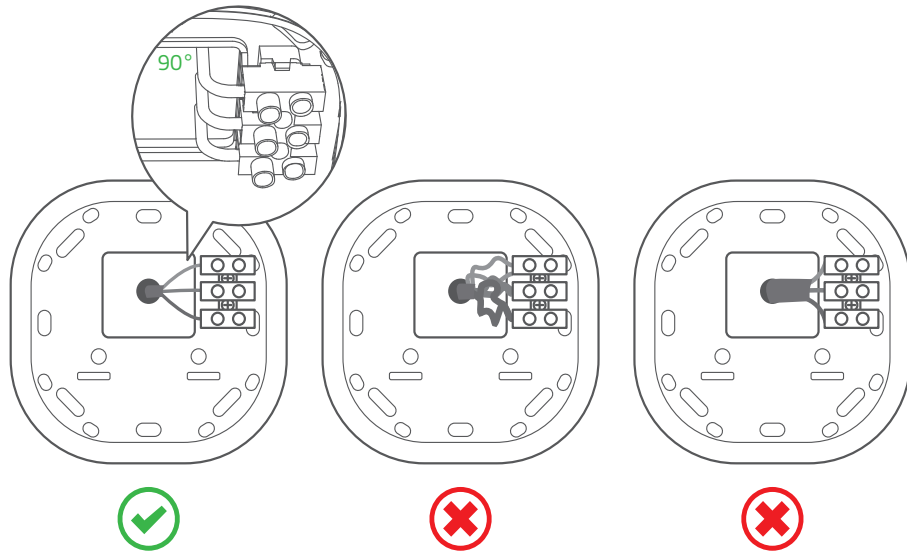

6. Desaperte os parafusos dos fios, insira os fios neutro, de terra e de corrente nos conectores e depois aperte os parafusos dos fios para fixar bem os fios.

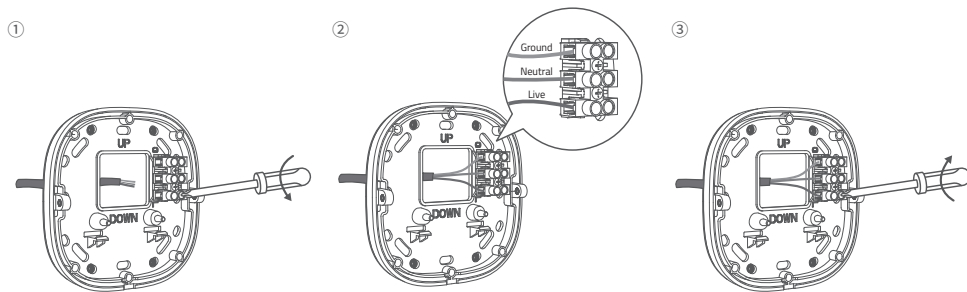

	América do Norte	Europa
Terra	Verde/amarelo	Verde/amarelo
Neutro	Branco	Azul
Corrente	Preto	Castanho

 As cores dos fios variam consoante a região.

7. Monte o dispositivo no suporte de montagem e fixe-o com um parafuso em cada lado.

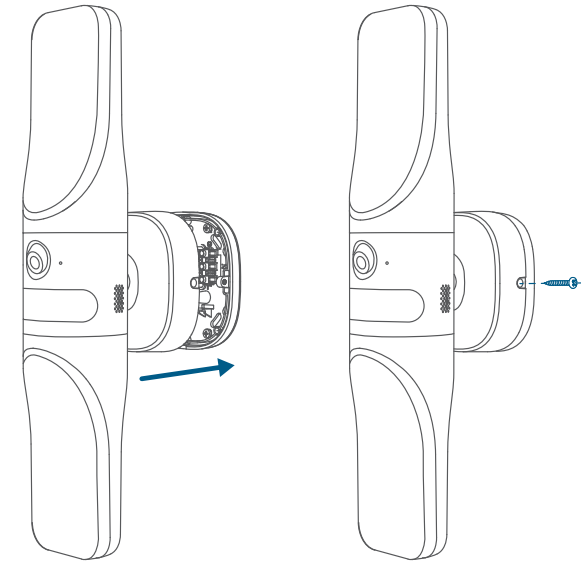

8. Ligue o disjuntor de sua casa.

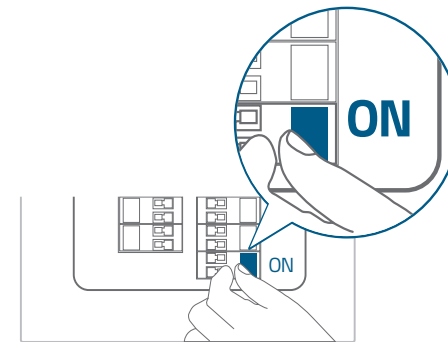

ÂNGULOS DE AJUSTE

1. Rode o dispositivo enquanto verifica a transmissão em direto a partir da aplicação eufy Security até obter a vista desejada.

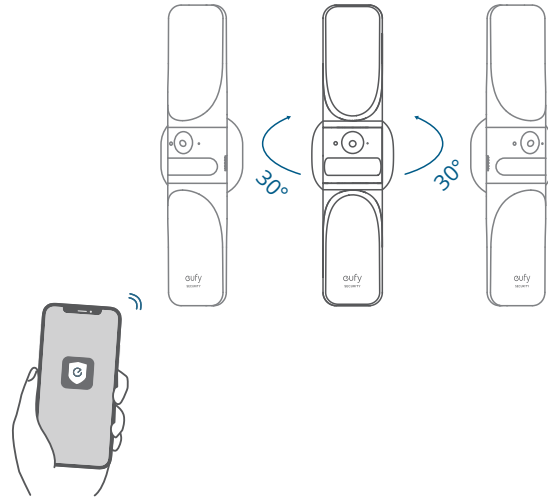

2. Vire a luz para encontrar o melhor ângulo para iluminar o espaço.

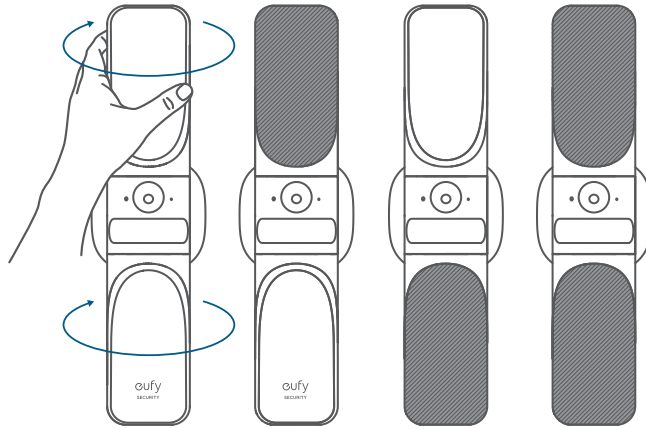

نظرة سريعة

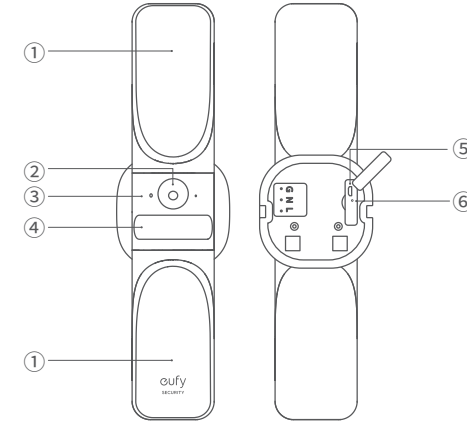

- ① مصباح
- ② عدسة الكاميرا
- ③ مؤشر LED الحالة
- ④ مستشعر الحركة
- ⑤ منفذ Micro USB
- ⑥ فتحة إعادة التعيين

ال لوازم المضمّنة



كاميرا مصباح الحائط S100



قاعدة التركيب

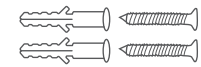

برغي القاعدة



برغي تثبيت الكاميرا



كابل USB



دليل البدء السريع

إعداد النظام

1. افتح غطاء منفذ USB الموجود في الجزء الخلفي من الجهاز، ثم وصله بالطاقة باستخدام الكابل المتوفر. سيظهر مؤشر LED الحالة باللون الأحمر عندما يكون الجهاز جاهزاً للإعداد.

3. امسح رمز الاستجابة السريعة الموجود على الجزء الخلفي من الجهاز أو دليل البدء السريع، ثم اتبع التعليمات التي تظهر على الشاشة لإكمال الإعداد.

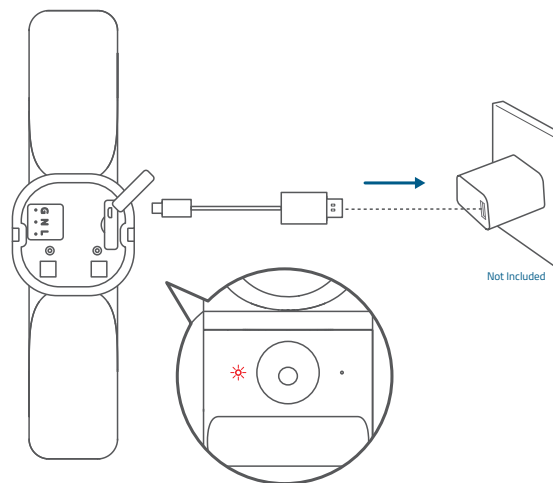
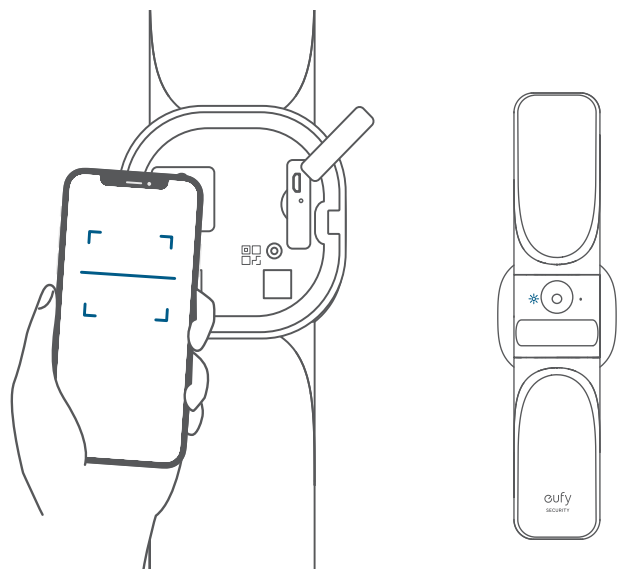

* لن تعمل المصابيح الرئيسية أثناء تشغيل الجهاز عبر منفذ USB.

4. افصل الجهاز عن الطاقة وأغلق غطاء منفذ USB، ثم أتمن المقابس المطاطية.

2. نزل تطبيق eufy Security وثبته، ثم قم بإعداد حساب.

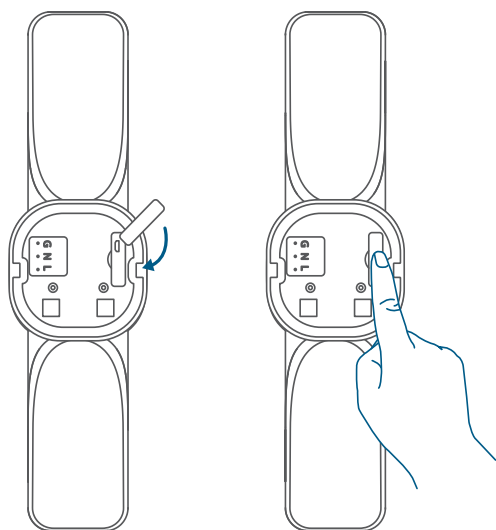

3. إذا كان هناك حامل لمصباح سابق، قم بإزالته قبل المتابعة.

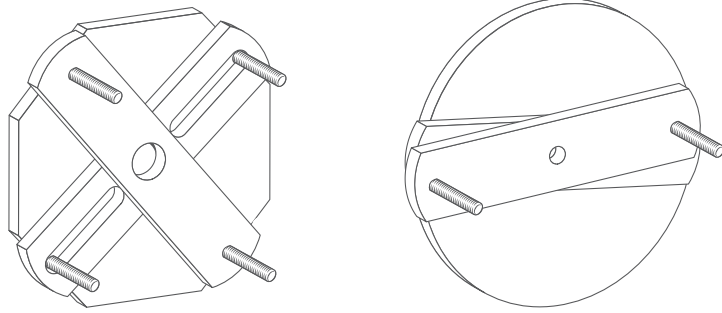

لتجنب خطر التعرض لصدمة أو الإصابة أو الوفاة، توخ الحذر دائماً عند التعامل مع الكهرباء. استعن بفني كهرباء محترف إذا كنت تشك في قدرتك على التعامل مع الأسلاك الكهربائية.

1. أوقف تشغيل قاطع الدائرة الكهربائية في منزلك. تحقق من انقطاع التيار الكهربائي في منزلك عن طريق تشغيل وإطفاء الأنوار.

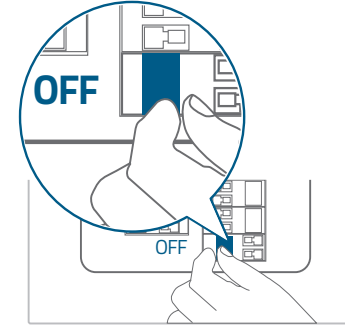

2. حدد وميز موقع التركيب على جزء مسطح من الجدار.

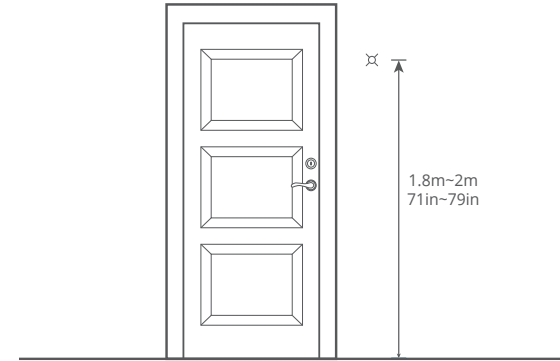

للحصول على أفضل تجربة لاكتشاف الحركة:

- تأكد من وضع الجهاز على سطح مستو ومن تركيب الجهاز بشكل مواز للحائط. لا يتم بتركيب الجهاز بإمالة لأعلى أو لأسفل.
- قم بتركيب الجهاز على ارتفاع بين 1.8 متر/ 71 بوصة ومترين/79 بوصة فوق سطح الأرض في منطقة اكتشاف الحركة. لا قم بتركيب الجهاز على ارتفاع يزيد عن 2.2 متر/ 87 بوصة فوق سطح الأرض.

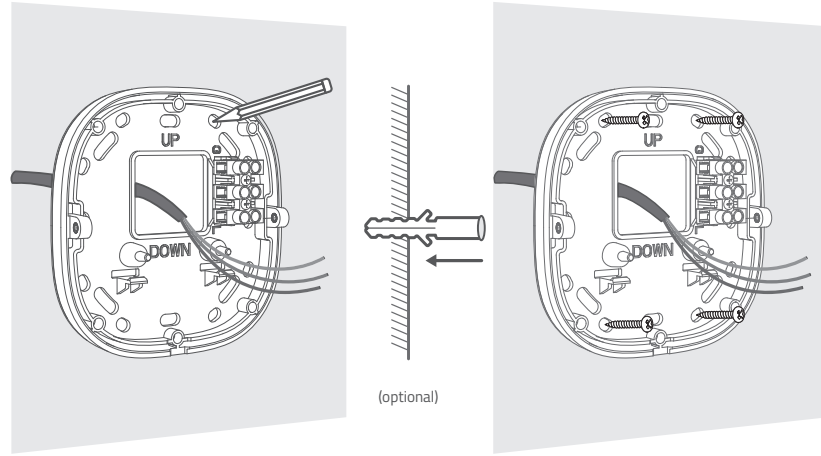

5. لتجنب الصعوبة عند تركيب الجهاز على حامل التثبيت:

- تأكد من أن الأسلاك ليست سميكة للغاية.
- حاول ثني الأسلاك بزاوية 90 درجة.

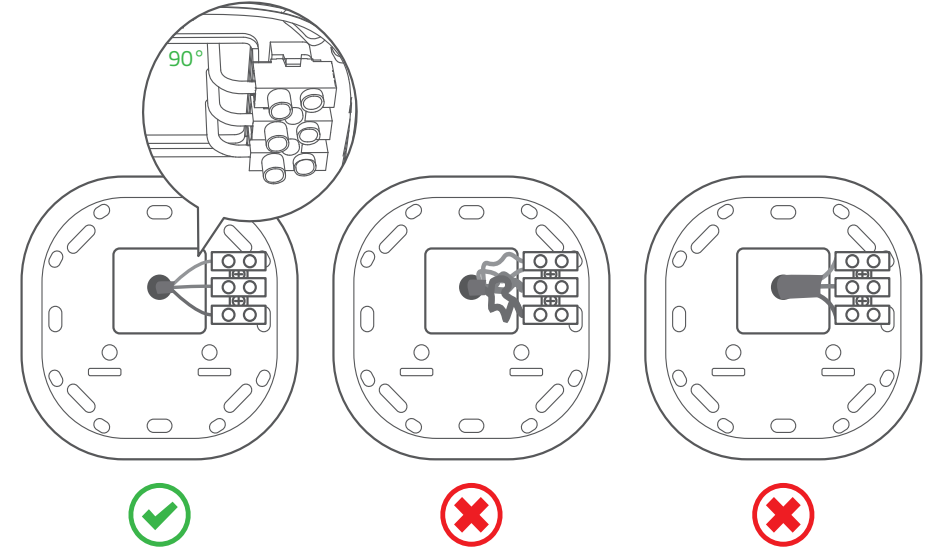

7. ركب الجهاز على كتيفة التثبيت، ثم ثبتها بمسمار من كل جانب.

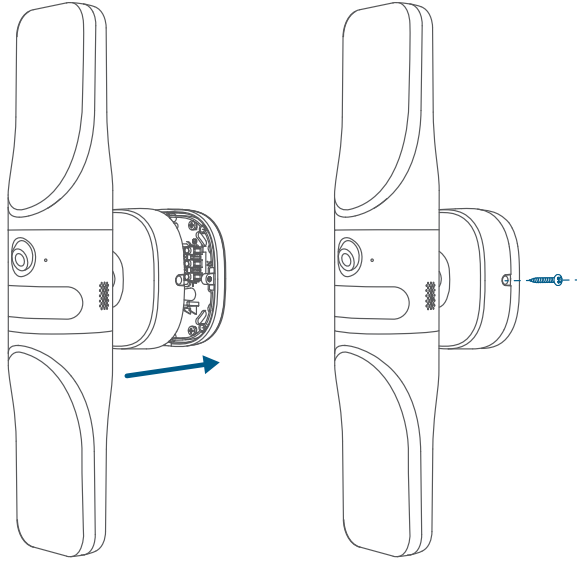

8. أعد تشغيل قاطع الدائرة الكهربائية في منزلك.

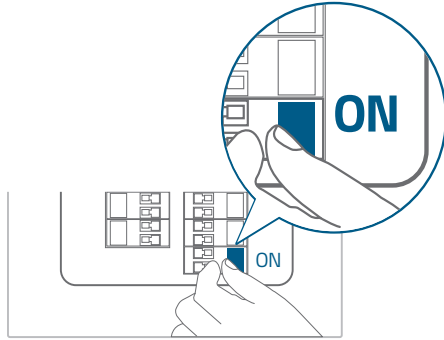

6. قم بفك براغي الأسلاك، وأدخل الأسلاك المحايدة والأرضية والحاملة للتيار في الموصلات، ثم أحكم ربط براغي السلك لتأمين الأسلاك تمامًا.

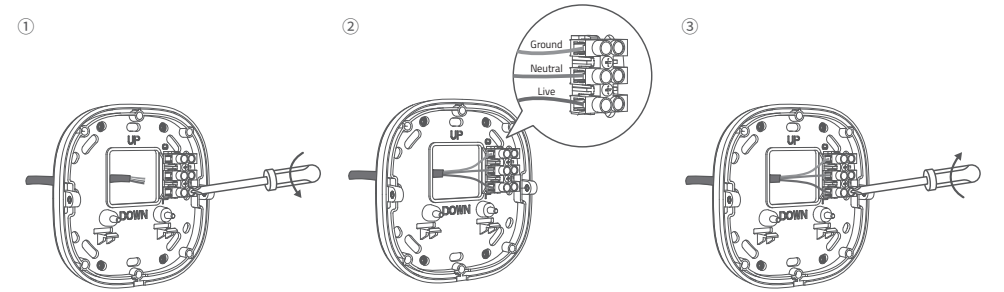

تختلف ألوان الأسلاك حسب المنطقة.



	أمريكا الشمالية	أوروبا
أرضي	أخضر / أصفر	أخضر / أصفر
محايد	أبيض	أزرق
حامل التيار	أسود	بنّي

ضبط الزوايا

1. اقلب الجهاز أثناء التحقق من البث المباشر من تطبيق eufy Security حتى تحصل على العرض المطلوب.

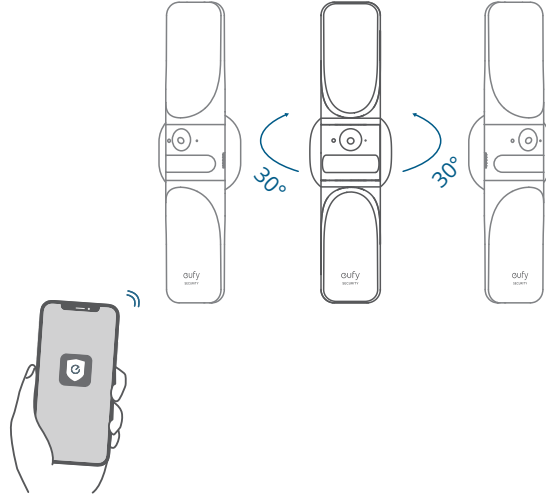

2. أدر الضوء للعثور على أفضل زاوية لإضاءة مساحتك.

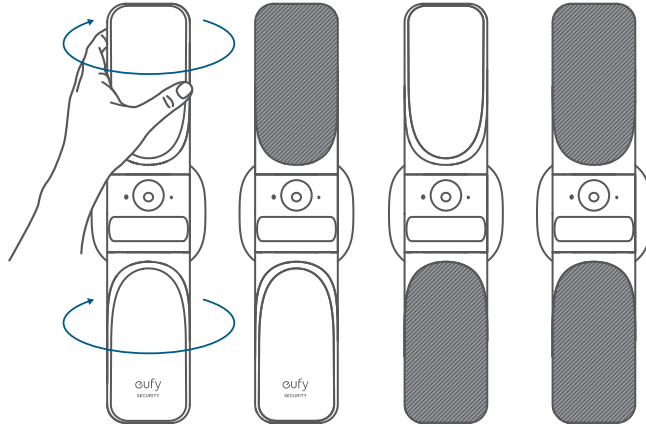

Customer Service

Kundenservice | Servicio de atención al cliente | Service client | Servizio clienti | Klantenservice | Serviço de Apoio ao Cliente | خدمة العملاء

📄 12-month limited warranty | 12 Monate eingeschränkte Garantie | Garantía limitada de 12 meses | Garantie limitée de 12 mois | Garanzia limitata di 12 mesi | 12 maanden beperkte garantie | 12 meses de garantía limitada | ضمان محدود لمدة 12 شهرًا

☎ (US) +1 (800) 988-7973
(UK) +44 (0) 1604 936200
(DE) +49 (0) 69 9579 7960
(中国) +86 400 0550 036
(日本) 03 4455 7823
(AU) +61 3 8331 4800
(Egypt) +20 8000000826
(UAE) +971 8000320817
(Kuwait) +965 22069086
(Saudi Arabia) +966 8008500030
(Middle East & Africa) +971 42428633

✉ support@eufylife.com

Anker Innovations Limited
Room 1318-19, Hollywood Plaza, 610 Nathan Road, Mongkok, Kowloon,
Hong Kong

📱 @EufyOfficial 📺 @EufyOfficial 📷 @EufyOfficial