



Version 202205

The background of the cover is a photograph of a large array of solar panels installed on a roof. The panels are dark blue with silver grid lines. The image is taken from a low angle, looking up the slope of the roof. In the background, there are green trees and a clear blue sky. A semi-transparent watermark with the text "we love smart" and a circular graphic is visible over the middle of the image.

***Installation Guide for Bluesun
Solar Shingled Single-Glass
PV Module***

Contents

| | | |
|-----|--|----|
| 1 | Scope | 2 |
| 2 | The introduction of installation manual | 2 |
| 2.1 | Overview | 2 |
| 2.2 | Applicable products | 2 |
| 3 | Product information | 3 |
| 3.1 | Section structure and component description of modules | 3 |
| 3.2 | Module tag information | 4 |
| 4 | Installation | 4 |
| 4.1 | General safety | 4 |
| 4.2 | Electrical properties safety | 5 |
| 4.3 | Handling safety | 6 |
| 4.4 | Installation safety | 6 |
| 5 | Installation condition | 7 |
| 5.1 | Working environment | 7 |
| 5.2 | Installation position | 8 |
| 5.3 | Tilt angle selection | 8 |
| 6 | Mechanical installation | 9 |
| 6.1 | Conventional requirement | 9 |
| 6.2 | Three kinds of Mounting | 10 |
| 6.3 | Installation methods | 11 |
| 6.4 | Wiring method | 15 |
| 7 | Electrical installation | 18 |
| 7.1 | Electrical property | 18 |
| 7.2 | Cables and wiring | 19 |
| 7.3 | Connectors | 19 |
| 7.4 | Bypass diodes | 19 |
| 7.5 | Grounding | 20 |
| 8 | Maintenance and care | 21 |
| 8.1 | Cleaning | 21 |
| 8.2 | Visual inspection | 22 |
| 8.3 | Inspection of connector and cable | 22 |
| 9 | Disclaimer of liability | 22 |

1 Scope

This installation manual specifies the installation and maintenance requirements for crystalline silicon PV modules (hereinafter referred to as "modules") manufactured by Bluesun Solar Co., Ltd. (hereinafter referred to as "Bluesun").

This installation manual is intended for the installation and maintenance of PV modules, and helps customers to correctly install the photovoltaic power generation system, so that the design system can realize its potential. This installation manual does not apply to the installation of the Bluesun double glass modules.

2 The introduction of installation manual

2.1 Overview

Thanks for choosing the crystalline silicon PV module of Bluesun Solar Co., Ltd. This manual contains important electrical and mechanical installation information. For correct installation and stable power output, please install and maintain the modules, please read and understand all installation instructions in the manual carefully, and keep this manual in a safe place as future reference (care and maintenance) and in case of sale or disposal of the modules.

This manual does not constitute a warranty, expressed or implied. Bluesun does not assume responsibility and expressly disclaims liability for loss, damage, or expense arising out of or in any way connected with installation, operation, use or maintenance of modules.

The PV modules should be installed in accordance with all safety precautions and local laws and regulations of this manual and should be installed and serviced by qualified personnel with knowledge of the mechanical and electrical requirements of the system.

The mechanical and electrical installation of the PV modules shall be made in accordance with applicable laws and regulations, including electrical, construction and electrical connection requirements. These regulations vary depending on the installation site, such as building roofs, surface mounts, in-vehicle applications, and so on. The requirements may vary depending on the installation system voltage, the use of DC or AC. Please refer to the relevant local laws and regulations.

Any questions, please contact with the salesman or customer service personnel of Bluesun solar for further explanations.

2.2 Applicable products

This manual is intended for use with the following module types:

Monocrystalline PV modules:

BSMxxxCM5-72S, BSMxxxCM5-60S

Monocrystalline PERC PV modules (Horizontal):

BSMxxxPM5-78S, BSMxxxPM5-78SA, BSMxxxPM5-78SAF, BSMxxxPM5-78SAS,
BSMxxxPMB5-78S, BSMxxxPMB5-78SA, BSMxxxPMB5-78SAF, BSMxxxPMB5-78SAS,
BSMxxxPM5-72S, BSMxxxPM5-72SA, BSMxxxPM5-72SB, BSMxxxPM5-72SBF,
BSMxxxPM5-72SBS, BSMxxxPMB5-72SB, BSMxxxPMB5-72SBF, BSMxxxPMB5-72SBS
BSMxxxPM5-66S, BSMxxxPM5-66SA, BSMxxxPM5-66SAF, BSMxxxPM5-66SAS,
BSMxxxPMB5-66S, BSMxxxPMB5-66SA, BSMxxxPMB5-66SAF, BSMxxxPMB5-66SAS,
BSMxxxPM5-60S, BSMxxxPM5-60SA, BSMxxxPM5-60SB, BSMxxxPM5-60SBF,
BSMxxxPM5-60SBS, BSMxxxPMB5-60SB, BSMxxxPMB5-60SBF, BSMxxxPMB5-60SBS

Monocrystalline PERC PV modules (Vertical):

BSMxxxPMB7-46SC, BSMxxxPMB7-46SCS, BSMxxxPMB7-46SCF

BSMxxxPM6-54SC, BSMxxxPMB6-54SC, BSMxxxPM6-65SC, BSMxxxPMB6-65SC
BSMxxxPM6-57SC, BSMxxxPMB6-57SC, BSMxxxPM6-68SC, BSMxxxPMB6-68SC
BSMxxxPM6-58SC, BSMxxxPMB6-58SC, BSMxxxPM6-69SC, BSMxxxPMB6-69SC

Module dimensions and electrical performance data are details in the corresponding technical specifications.

3 Product information

3.1 Section structure and component description of modules

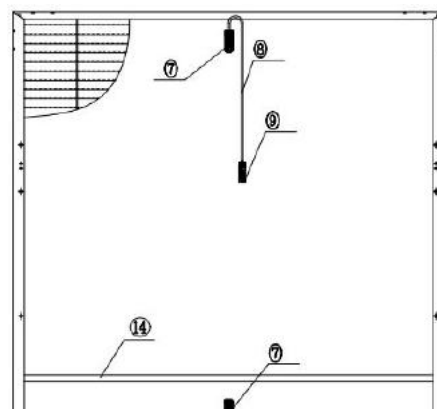
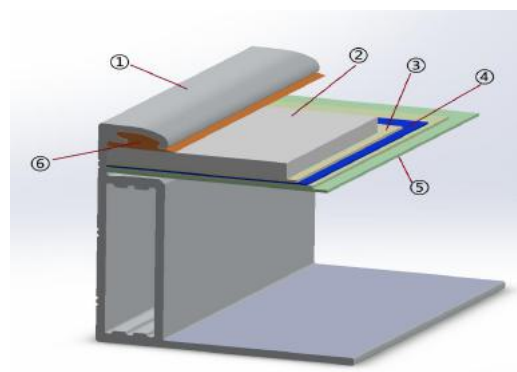

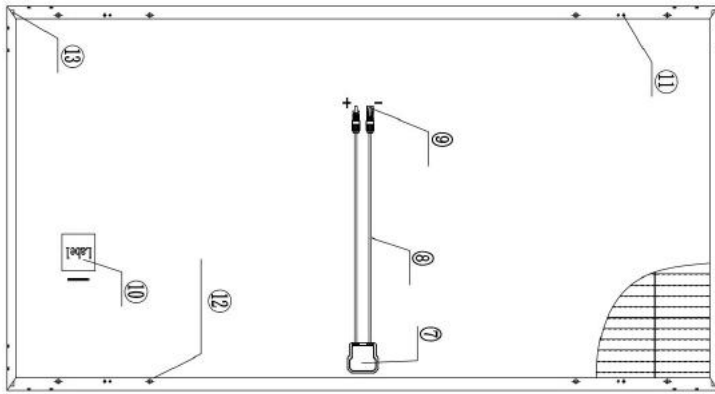

| Horizontal | | Vertical | |
|-------------------|---------------|-----------------|-------------------|
| 1、 Frame | 2、 Glass | 3、 EVA | 4、 Solar Cell |
| 5、 Backsheet | 6、 Adhesive | 7、 Junction box | 8、 Cable |
| 9、 Connector | 10、 Label | 11、 Ground hole | 12、 Mounting hole |
| 13、 Drainage hole | 14、 Stiffener | | |

Figure 1 Section structure and module description

3.2 Module tag information

Each PV module is affixed with two kinds of labels, providing the following information:

- a) Label: Describes the product name, PV module model, nominal power, rated voltage, rated current, open circuit voltage, short circuit current, maximum system voltage, PV module size and weight under standard test conditions.
- b) Series number: Each module has a unique bar code number, each bar code number has 20 letters and numbers. The bar code is permanently encapsulated inside the module, as can be seen clearly from the top right corner of the module. The bar code number allows you to trace information about the module production process.

3.3 Module electrical performance parameters

The electrical performance parameters of the module were measured under standard test conditions (irradiance of 1000 W / m², AM 1.5 spectra, ambient temperature of 25 ° C) with a test uncertainty of ± 3%. The maximum system module voltage is 1500V.

4 Installation

4.1 General safety

4.1.1 Bluesun solar's modules have been evaluated by according to IEC61215 and IEC61730, Protection Class II, modules rated for use in this protection class may be used in system operating at greater than 50V DC or

240W. The class of fire rating is Class C (According to the standard is UL790) .

4.1.2 The maximum rating of a fuse connected in series with an array string is typically 20A, but the actual module specific rating can be found on the product label and in the product datasheet.

4.1.3 The installer should abide by the relevant local laws and regulations when installing module. It is need to obtain the required certificates in advance when necessary, such as the building permit.

4.1.4 Installing solar systems require specialized skills and knowledge. Installation should be performed only by qualified person. Installers should assume the risk of all injuries that might occur during installation, such as electric shock.

4.1.5 PV modules are designed for outdoor use, modules may be mounted on ground, rooftops, vehicles or boats. Proper design of support structures is the responsibility of the system designers or installers. When modules are mounted on rooftops, fire-protection rating of the final structure should be considered, and also the later maintenance. The rooftops and support structure for PV system should only be certified by architectural experts or engineer, which have a formal complete structure analysis results.

4.1.6 For your safety, do not install the modules without safety precautions.

4.1.7 For your safety, do not install or handle the modules under wet or adverse environment, including but not limited to strong wind, gusty wind, frosted roof surfaces, wet environment.

4.1.8 Meaning of crossed –out wheeled dustbin:

Do not dispose of electrical appliances as unsorted municipal waste, use separate collection facilities.

Contact your local government for information regarding the collection systems available.

If electrical appliances are disposed of in landfills or dumps, hazardous substances can leak into the groundwater and get into the food chain, damaging your health and well-being.

When replacing old appliances with new ones, the retailer is legally obligated to take back your old appliance for disposals at least free of charge.



4.2 Electrical properties safety

4.2.1 When a module is exposed to sunlight or other light sources, a direct current is present inside the module, and electrical contact with the module may result in an electrical shock hazard.

4.2.2 In order to avoid arc and electric shock, please do not disconnect electrical connections under load. Keep all electrical connectors dry and clean, and ensure that they are in proper working condition. Do not insert other metal objects into the connector, or in any other way.

4.2.3 Do not apply paint or adhesive to module surface. Do not wipe modules with corrosive chemicals.

4.2.4 Do not use mirrors or other magnifiers to focus sunlight on the modules. Do not expose the backside of modules directly to sunlight for a long time.

4.2.5 Do not change the configuration of the bypass diodes. Do not disassemble the modules.

4.2.6 Do not contact with module surface when the module is wet unless to clean the modules, please following requirements mentioned in this manual when cleaning.

4.3 Handling safety

4.3.1 Do not open the box until it reaches the installation location. Keep the package in a dry and dry place.

4.3.2 PV modules Unpacking Please refer to Unpacking manual of standard package of Bluesun solar photovoltaic modules. During all handling procedures, make sure that the modules are not subject to large vibrations, that the modules fall to the floor or that objects fall on the module, as this will Damage to the modules or solar cell. Special care must be taken not to bump, scrape, or press against the back of the module. Keep children and unauthorized person away from the modules while transporting or installing them. Improper transportation or placing may lead to glass breakage or power loss of the modules, resulting in the loss of the use value of modules.

4.3.3 Handle modules with care, lift and put down modules gently. It is forbidden to carry or lift the modules by grabbing the junction box or cables. Two or more people must hold the module with both hands.

4.3.4 Do not step on, stand or sit on the module, which can damage the module and create a risk to people.

4.3.5 Do not place any heavy objects on the front or back of the module, and do not place the module on a sharp object surface.

4.4 Installation safety

4.4.1 Abide by the safety regulations for all other modules used in the PV system, including wiring and cables, connectors, controllers, inverters, storage batteries, etc., and use suitable equipment, connectors, wiring and mounting system for a PV system. If the PV system is used in storage batteries, the configuration with the modules should follow the advice of the storage batteries manufacturer. The same size, the same specifications of the model can be connected in series.

4.4.2 Do not install or handle the modules when they are wet or during strong wind. Keep the junction box's cover closed.

4.4.3 Modules of the glass with the role of protection modules, unreasonable operation will cause glass broken. Damaged modules have the risk of electric shock and fire, such modules can not be repaired or repaired, should be replaced immediately.

4.4.4 When exposed to direct sunlight, one individual solar module may generate DC voltages greater than 30 volts. It is extremely dangerous to contact it.

4.4.5 To reduce the risk of electric shock or burning, you can install modules with opaque material on the surface of the module. The mounting of the array of modules must be carried out with an isolating solar installation. Do not wear metal rings, watches, earrings and other metal accessories when installing or servicing PV systems. Do not touch the electrical parts of the module directly by hand. Use an insulating tool to make electrical connections and keep the tool dry.

4.4.6 The triangle hole punched on the backside frame of the module is the drainage hole which cannot be blocked.

4.4.7 The maximum system voltage indicated in the rating label is 1500 V. During the system Installation, the maximum open circuit voltage in series cannot exceed the maximum system voltage.

4.4.8 During modules interconnection, ensure to fix the connecting cables to supporting bracket, so as to restrict the swing amplitude of the slack part of the cables.

4.4.9 Abide by the allowable minimum bending radius of the cables (suggest no less than 43mm).

4.4.10 Always protect the cable with conduit where animals or children can touch it.

4.4.11 Please use the connector which is specially designed for photovoltaic system, and assemble it with the tools recommended or specified by the manufacturer. In case that the connector applicable to the solar photovoltaic system is required, please contact the local supplier. Ban different connectors to plug each other.

4.4.12 Make sure that the polarity is correct when connecting the module with inverter, storage battery or combiner box to avoid the damage of bypass diodes in the modules due to incorrect polarity.

4.4.13 Do not drill holes in the frame, this may reduce the mechanical load ability and cause corrosion of the frame.

4.4.14 Do not scratch the anodized coating of the frame (except for grounding connection), this may cause corrosion of the frame or reduce the mechanical load ability.

4.4.15 Modules can't be used to replace the roof and wall materials, partial replacement is not allowed.

4.4.16 Any part (including nameplate) of modules supplied by Bluesun Solar Co., Ltd can't be dismantled without permission.

5 Installation condition

5.1 Working environment

Bluesun solar's PV module should operate in the following environmental conditions:

5.1.1 Ambient temperature: -20°C to +45°C

5.1.2 Operating temperature of the module: -40°C to +85°C

5.1.3 Humidity: 85%RH

5.1.4 Mechanical load bearing capacity: the modules have passed the mechanical load test of wind pressure of

1200Pa and snow pressure of 5400Pa; at the same time, they have passed the mechanical load test of wind pressure of 2400Pa and snow pressure of 3600Pa. (Only limited to the PV module models mentioned in this manual).

Note: The module mechanical load is based on the installation method and installation site, in the calculation of mechanical load by the professional installer according to the system design requirements to calculate.

5.2 Installation position

5.2.1 In most applications, PV modules should be installed in a location where they will receive maximum sunlight throughout the year. In the northern hemisphere, modules should typically face south, and in the southern hemisphere, modules should typically face north.

5.2.2 The module shall be installed in the place where the sunshine is adequate. the module surface shall not be partly shaded by trees, building, clothes, tools, packaging materials, etc. because these objects will form shadow in the module surface leading to loss of system output power.

5.2.3 The module shall be installed in the well-ventilated place; meanwhile, enough space for airiness shall be sated at the back and sides of the module, so that the heat generated during operation can be radiated in time.

5.2.4 Modules can not be used in other excessive and harsh environments, such as hail, snow, sand, smoke, air pollution, soot, flammable gases, near open flames, and highly corrosive substances (such as acid rain) , As this will affect the module's safety and performance. If the installation environment is special, such as farm, high humidity or wind and other large environment, please consult your local dealer for professional support and confirmation. If you need to be installed at a high altitude, the altitude should not exceed 2000m.

5.2.5 Bluesun PV modules have passed IEC61701 salt-mist, but galvanic corrosion can occur between the aluminum frame of the modules and mounting or grounding hardware if such hardware is comprised of dissimilar metals. Bluesun modules can be installed at seaside locations 50m to 500m from the sea, but the components should be protected against corrosion. For locations ≥ 500 m from the sea, it is low risk with salt-mist corrosion, only annual preventive maintenance is required.

5.2.6 Modules should be installed in suitable buildings, or other suitable place to install modules (such as the ground, garage, building facades, roof).

5.2.7 If modules are installed in locations with frequent lightning activity, the modules must be protected against lightning strikes.

5.2.8 Do not install the modules in this location with water immersion or near the sprinkler.

5.2.9 The pressure of the wind or snow after installation of the modules must not exceed the maximum allowable load.

5.3 Tilt angle selection

5.3.1 The tilt angle of the Modules is measured between the surface of the modules and a horizontal ground surface, the modules generates maximum power output when it faces the sun directly, as shown in figure 2.

5.3.2 Modules each element in series with the same array must be oriented in the same direction and angle. Different installation directions and angles will cause the modules to absorb the total solar radiation difference, causing the loss of output power, thus reducing the operating efficiency of the system.

5.3.3 The maximum power is generated when the sun is directed to the module, select the best installation angle should be considered when the winter module power output. But external or otherwise artificially

concentrated sunlight shall not be directed onto the front or back face of the PV module.

5.3.4 In order to facilitate the cleaning modules and modules in the rain when the surface dust is easily washed away by rain. For detailed installation angles, follow the advice given by the experienced PV module installer.

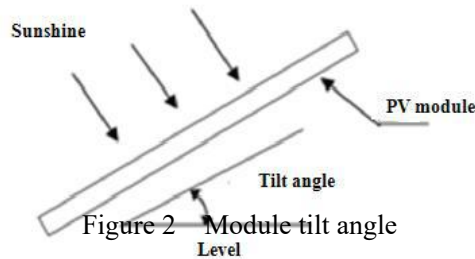

6 Mechanical installation

All of the installation methods described here are for reference only. Bluesun Solar Co., Ltd is not responsible for providing the relevant installation parts and module installation services.

6.1 Conventional requirement

6.1.1 Ensure that the installed modules and supporting rail of modules are strong enough, the entire PV system consisting of modules must be able to withstand anticipated mechanical pressure. The installer must provide the guarantee. The installation supporting rail must be tested by the third-party organization with the analysis ability of Static Mechanical according to the local national or international standards.

6.1.2 The supporting rail must be made of environmental corrosion, anti-rust and UV-resistant materials.

6.1.3 Modules must be securely fastened to the supporting rail.

6.1.4 Drilling holes on the surface of module glass or drilling additional mounting holes on module frames may void the warranty.

6.1.5 Forces generated during thermal expansion and contraction of the supporting rail may influence the performance and use of the module, so make ensure that the minimum distance between two neighboring frames is 10mm, but in order to ensure good ventilation. Suggest this distance between two neighboring frames is 30mm.

6.1.6 In areas with large snow cover in winter, select a higher mounting bracket so that the lowest point of the module will not be covered by snow for long periods of time. In addition, the lowest point of the module is high enough to prevent the module from being obstructed by vegetation or trees.

6.1.7 The bearing surface of the supporting system must be smooth without any twist or deformation, and all of them shall be at the same height without dislocation.

6.1.8 The module mounting method does not result in electrochemical corrosion between the aluminum frame of the module and the different metals.

6.2 Three kinds of Mounting

6.2.1 Roof mounting

6.2.1.1 It is necessary to provide a special supporting rail for the roof mounting. When installing a module on a roof or building, ensure that it is securely fastened and cannot fall or be damaged as a result of strong winds or heavy snow. During roof mounting, check the building codes being used to ensure that the building and its structure where the module is installed have adequate bearing and sealing capacity. The roof when penetrated during module installation shall be properly sealed to avoid rainwater leakage.

6.2.1.2 To be suitable for operation, reduce steam condensation and facilitate the ventilation & heat dissipation of the module during tile installation, the module shall be parallel to the wall or roof surface of the building, and the distance between module and surface of the wall or roof shall be at least 115mm to prevent wiring damage and to allow air circulation, ventilation and heat dissipation behind the module. For stacking type installation, the module shall be installed on the fire-resistant roof. The Fire Resistance Rated Class of the modules is Class C, and the modules are suitable for mounting on an above Class A roof. Do not install modules on a roof or building during strong wind.

6.2.1.3 For the roof system installed in the area with relatively heavy snowfall or snow cover in the meteorological records, the installer shall reinforce the supporting system at the lower frame of the module, in order to prevent the lower frame from being pressed and damaged by the falling snow or freezing of the melted snow. Bluesun solar suggests selecting the support reinforcing mechanism shown in figure 3.

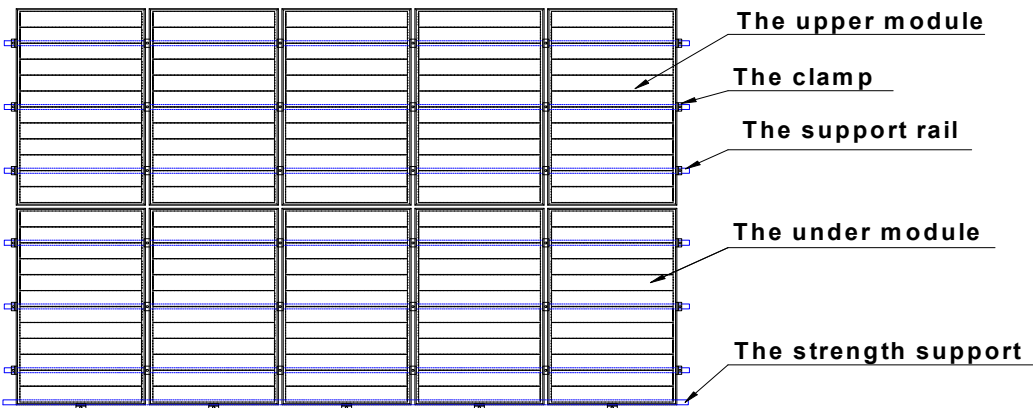

Figure 3 Schematic diagram of reinforcement mounting of module

6.2.2 Pole mounting

When installing a module on a pole, choose a pole and supporting rail that will withstand the anticipated wind power of the local area. The pole must be constructed on a solid foundation.

6.2.3 Ground mounting

Select the height of the mounting system to prevent the lowest edge of the module from being covered by snow for a long time in winter in areas with heavy snowfalls. The module shall be installed on the supporting

rail with appropriate height instead of being directly laid on the ground. In addition, the lowest portion of the module shall be high enough (≥ 900 mm) from ground, so that it is not shaded by plants and trees, or damaged by sand and stone driven by wind, or not shaded by the mud splashed by rain water.

6.3 Installation methods

6.3.1 General rules

- a) Modules can be fastened on the supporting system using clamps. Modules must be installed according to the following methods or instructions. If not the warranty may be void.
- b) Bluesun modules have reached the IEC standard on the mechanical load requirements. When mounting, use the pressure clamp to secure the module to the supporting rail, Bluesun module can withstand the wind pressure of 2400Pa and the snow pressure of 5400Pa (Only the module models covered in this manual are available), it is recommended that the system designer or installer perform the load calculations.
- c) The supporting rail and other materials required shall be made of durable, resistance to environmental corrosion, anti-rust and UV-resistant materials.

6.3.2 Fixture installation

6.3.2.1 Use a certain number of clamps to fix the modules on the mounting bracket. Bluesun recommends that the clamps be clamped on the long frame of the module. The area of the A side of the module frame held by each fixed clamp is not less than 400mm^2 (clamp length: $\geq 50\text{mm}$, The width of the contact between the fixture and the A surface of the frame: $9\sim 11\text{mm}$).

6.3.2.2 When installing the fixing jig, do not touch the front glass, and do not scratch or deform the aluminum frame during installation. At the same time, the jig cannot affect the normal operation of the module. Make sure that the drain hole and ground hole are not blocked during installation.

6.3.2.3 Each module needs to be fixed with at least four fixtures, and each long frame is equipped with at least two fixtures. According to the local application conditions (actual conditions of wind and snow), additional fixtures may be required to ensure modules and systems are subjected to corresponding loads. Fixtures with the following conditions are recommended (as shown in Figure 4) or approved by the module system installer.

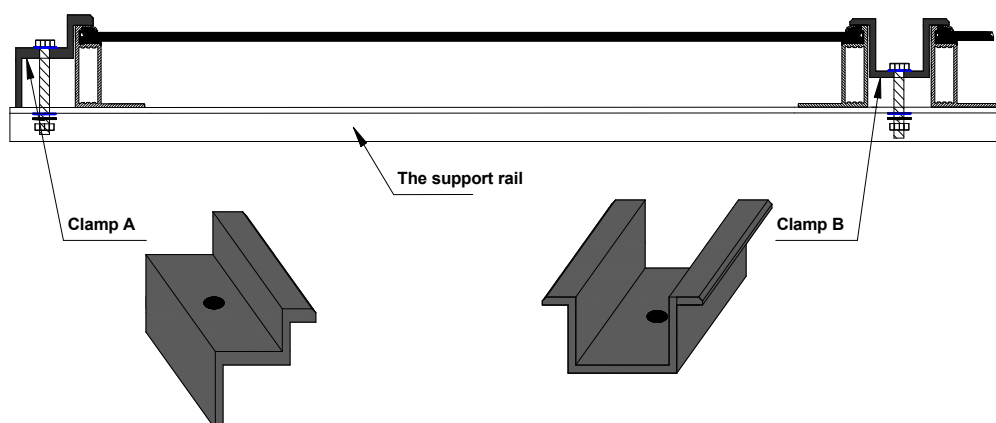

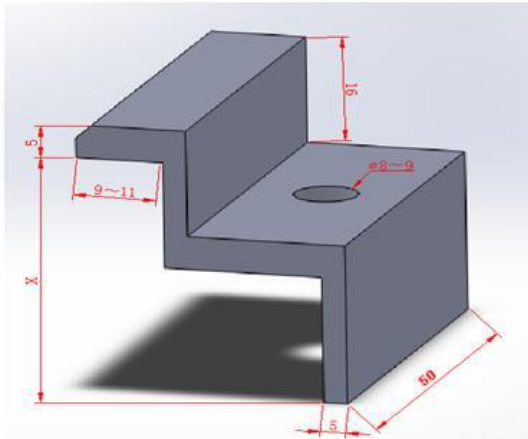

Fixture A: Fixture for edge module

For the 30 frame, the recommended value of X is 29mm

For the 35 frame, the recommended value of X is 34mm

For the 40 frame, the recommended value of X is 39mm

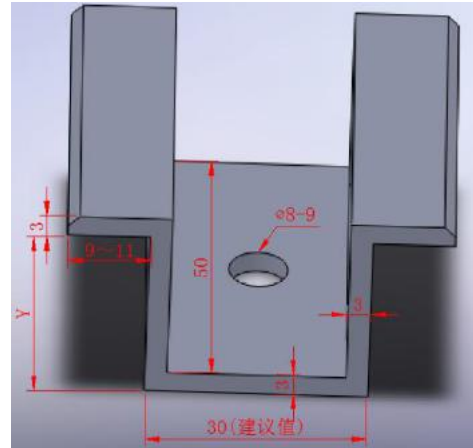

Fixture B: Fixture for intermediate modules

For the 30 frame, the recommended value of Y is 20mm

For the 35 frame, the recommended value of Y is 25mm

For the 40 frame, the recommended value of Y is 30mm

Figure 4 Assembly fixture installation method

6.3.2.4 When clamping the fixture to the frame of the module, use spring washers, flat washers and bolts to fix the module on the mounting frame. Note that both ends should be clamped in a symmetrical position in the center. M8 bolts and matching The screw is fixed, and the torque of the screw is 8N·m.

6.3.2.5 If there is large snowfall or snow pressure in the module installation area and large wind pressure, it is recommended that the customer adopt a 5400Pa reinforced installation solution to clamp the fixed module (as shown in Table 1 recommendations) to increase the front of the module Resistant to static snow pressure and dynamic wind pressure on the back, improving the system's pressure resistance.

Table 1 The clamping range of the fixture

| | |
|--|---|
| | <p>Note:</p> <p>A: Length of this type of module.</p> <p>B: Width of this type of module.</p> <p>C: The distance of clamp center1 from the edge of this type of module.</p> <p>D: The distance of clamp center 2 from the edge of this type of module.</p> <p>E: Clamped width of the module frame by the clamp of this type of module.</p> <p>F: Clamped length of the module frame by the clamp of this type of module.</p> <p>G: The distance of clamp center 3 from the long edge of this type of module.</p> <p>H: The distance of clamp center 4 from the edge of this type of module.</p> <p>Bolt beam: width * height * length 40mm*40mm* 1500mm</p> |
|--|---|

*** Note:** Bluesun limited warranty will be void in cases where improper clamps or installation methods deviating from this manual are used. When using clamps to fasten the modules, pay attention to the following requirements:

- (a) Take care of the module frames, not to twist or deform them.
- (b) Avoid the clamps' shading influence the module.
- (c) Not to damage the surface of module frame.
- (d) Make sure that the module's drainage holes not be plugged.

| Module Type | Installation method | Design load*safety factor(1.5)/Pa | A/mm | B/mm | C/mm | D/mm | E/mm | F/mm | G/mm | H/mm |
|--|---------------------------|--|------------------------------|------------------------------|--------------------------------------|----------------------------|------------------------------|--------------------------|--------------------------------------|--------------------------------------|
| BSMxxxCM5-72S /BSMxxxPM5-72S | Long side Installation | positive5400 negative2400 | 1942 | 1069 | 390±50 | 970±50 | 9~11 | ≥50 | / | / |
| BSMxxxPM5-72SA | Long side Installation | positive5400 negative2400 | 1969 | 1084 | 395±50 | 985±50 | 9~11 | ≥50 | / | / |
| BSMxxxPM5-78S BSMxxxPM5-78SA BSMxxxPM5-78SAF BSMxxxPM5-78SAS BSMxxxPMB5-78S BSMxxxPMB5-78SA BSMxxxPMB5-78SAF BSMxxxPMB5-78SAS | Long side Installation | positive5400 negative2400 | 1969 | 1140 | 395±50 | 985±50 | 9~11 | ≥50 | / | / |
| BSMxxxPM5-72SB BSMxxxPM5-72SBF BSMxxxPM5-72SBS BSMxxxPMB5-72SB BSMxxxPMB5-72SBF BSMxxxPMB5-72SBS | Long side Installation | positive5400 negative2400 | 2056 | 1140 | 410±50 | 1028±50 | 9~11 | ≥50 | / | / |
| BSMxxxCM5-60S /BSMxxxPM5-60S | Long side Installation | positive5400 negative2400 | 1622 | 1068 | 325±50 | / | 9~11 | ≥50 | / | / |
| BSMxxxPM5-60SA | Long side Installation | positive5400 negative2400 | 1646 | 1084 | 330±50 | / | 9~11 | ≥50 | / | / |
| BSMxxxPM5-66S BSMxxxPM5-66SA BSMxxxPM5-66SAF BSMxxxPM5-66SAS BSMxxxPMB5-66S BSMxxxPMB5-66SA BSMxxxPMB5-66SAF BSMxxxPMB5-66SAS | Long side Installation | Positive3600 negative3600 positive5400 negative2400 Positive3600 negative3600 positive5400 negative2400 | 1646 1646 1646 1646 | 1140 1140 1140 1140 | 330±50 330±50 330±50 330±50 | / / 823±50 823±50 | 9~11 9~11 9~11 9~11 | ≥50 ≥50 ≥50 ≥50 | / / / / / / / / | / / / / / / / / |
| BSMxxxPM5-60SB BSMxxxPM5-60SBF | Long side Installation | Positive3600 negative3600 | 1719 | 1140 | 345±50 | / | 9~11 | ≥50 | / | / |

| | | | | | | | | | | |
|--|---------------------------|------------------------------|------|------|--------|---|------|-----|---|--------|
| BSMxxxPM5-60SBS BSMxxxPMB5-60SB BSMxxxPMB5-60SBF BSMxxxPMB5-60SBS | | positive5400 negative2400 | 1719 | 1140 | 345±50 | / | 9~11 | ≥50 | / | / |
| BSMxxxPMB7-46SC BSMxxxPMB7-46SCS BSMxxxPMB7-46SCF | Long side Installation | positive5400 negative2400 | 1899 | 1096 | 380±50 | / | 9~11 | ≥50 | / | / |
| BSMxxxPM6-54SC BSMxxxPMB6-54SC | Long side Installation | Positive5400 negative2400 | 2253 | 1096 | 545±50 | / | 9~11 | ≥50 | / | 405±50 |
| BSMxxxPM6-57SC BSMxxxPMB6-57SC | Long side Installation | Positive5400 negative2400 | 2355 | 1096 | 570±50 | / | 9~11 | ≥50 | / | 425±50 |
| BSMxxxPM6-58SC BSMxxxPMB6-58SC | Long side Installation | Positive5400 negative2400 | 2384 | 1096 | 575±50 | / | 9~11 | ≥50 | / | 430±50 |
| BSMxxxPM6-65SC BSMxxxPMB6-65SC | Long side Installation | Positive5400 negative2400 | 2253 | 1303 | 545±50 | / | 9~11 | ≥50 | / | 405±50 |
| BSMxxxPM6-68SC BSMxxxPMB6-68SC | Long side Installation | Positive5400 negative2400 | 2355 | 1303 | 570±50 | / | 9~11 | ≥50 | / | 425±50 |
| BSMxxxPM6-69SC BSMxxxPMB6-69SC | Long side Installation | Positive5400 negative2400 | 2384 | 1303 | 575±50 | / | 9~11 | ≥50 | / | 430±50 |

6.3.2.6 For matters concerning clamp or installation not mentioned in this manual, contact the local dealer for professional support.

6.3.3 Screw installation

6.3.3.1 Use anti-corrosion M8 bolts to fix through the mounting holes on the module frame. Each module needs to be fixed on 8 mounting holes (Screw installation only applies to BSMxxxPM5-78S, BSMxxxPM5-78SA, BSMxxxPM5-78SAF, BSMxxxPM5-78SAS, BSMxxxPMB5-78S, BSMxxxPMB5-78SA, BSMxxxPMB5-78SAF, BSMxxxPMB5-78SAS, BSMxxxPM5-72SB, BSMxxxPM5-72SBF, BSMxxxPM5-72SBS, BSMxxxPMB5-72SB, BSMxxxPMB5-72SBF, BSMxxxPMB5-72SBS PV modules), as shown in Table 2 Schematic diagram of mounting holes for fixed modules. If you need to strengthen the installation, it is recommended to use the 6.3.2 fixture installation method.

6.3.3.2 When fixing with M8 bolts, spring washers and flat washers must be added to 8 symmetrical mounting holes. See Table 1 for bolt fixing diagrams. The recommended torque for tightening screws is 16N • m. The recommended accessories are shown in Table2:

Table 2 Bolt fixing assembly

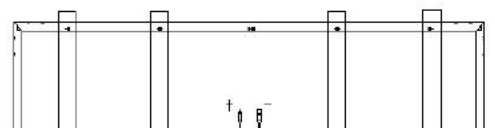
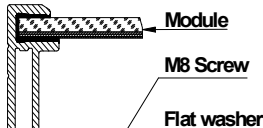
| Mounting holes location | Screw bolts fasten method | Recommend accessories | | |
|---|--|-----------------------|-----------------|-----------|
| | | Part name | material | Dimension |
|  |  | Screw | Stainless steel | M8× |

| | | | | 16mm |
|--|------------------------|-----------------------------------|---|-----------------------|
| | | | Spring washer | Stainless steel M8 |
| | | | Flat washer | Stainless steel M8 |
| | | | Nut | Stainless steel M8 |
| | | | Bolt beam: width * height * length 40mm*40mm* > 2000mm | |
| Module Type | Installation method | Design load*safety factor(1.5)/Pa | | |
| BSMxxxPM5-78S BSMxxxPM5-78SA BSMxxxPM5-78SAF BSMxxxPM5-78SAS BSMxxxPMB5-78S BSMxxxPMB5-78SA BSMxxxPMB5-78SAF BSMxxxPMB5-78SAS | Long side Installation | positive5400/negative2400 | | |
| BSMxxxPM5-72SB BSMxxxPM5-72SBF BSMxxxPM5-72SBS BSMxxxPMB5-72SB BSMxxxPMB5-72SBF BSMxxxPMB5-72SBS | Long side Installation | positive5400/negative2400 | | |

6.4 Wiring method

6.4.1 Wiring method of horizontal modules

| | |
|--|---|
| <p>Horizontal Installation (Double row , The junction box is inside)</p> | |
| | <p>The wire length of 72 / 78 is not less than 1200mm, and that of 60 / 66 is not less than 1000mm.</p> |

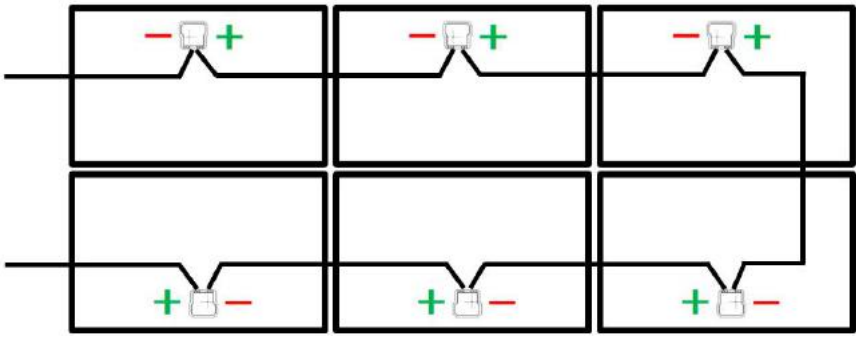
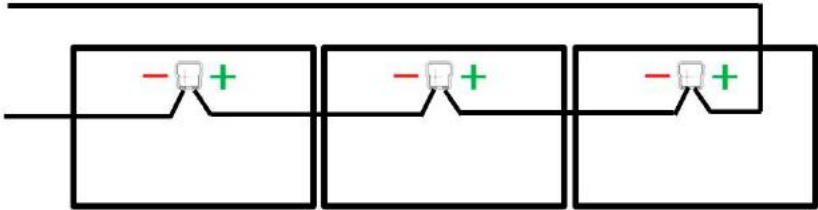
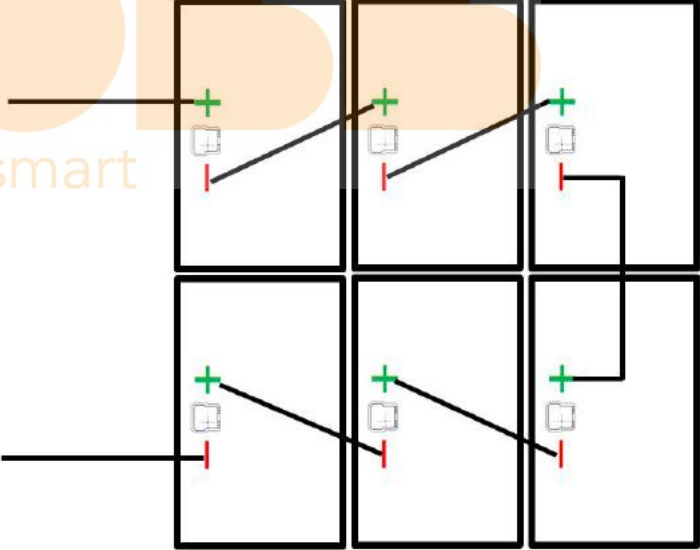
| | |
|--|---|
| <p>Horizontal Installation (Double row , The junction box is on the outside)</p> |  <p>The wire length of 72 / 78 is not less than 1200mm, and that of 60 / 66 is not less than 1000mm.</p> |
| <p>Horizontal Installation (Single row)</p> |  <p>The wire length of 72 / 78 is not less than 1200mm, and that of 60 / 66 is not less than 1000mm.</p> |
| <p>Vertical Installation (Double row)</p> |  <p>The wire length of 72 / 78 is not less than 700mm, and each string needs to add a jumper wire not less than 900mm. The wire length of 60 / 66 is not less than 700mm, and each string needs to add a jumper wire not less than 500mm.</p> |

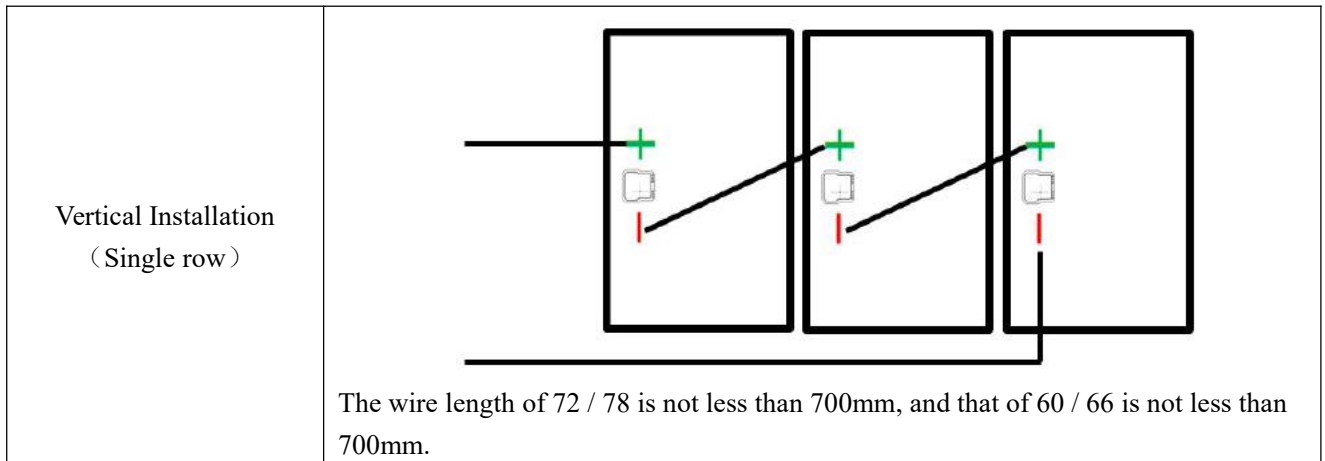

6.4.2 Wiring method of vertical modules

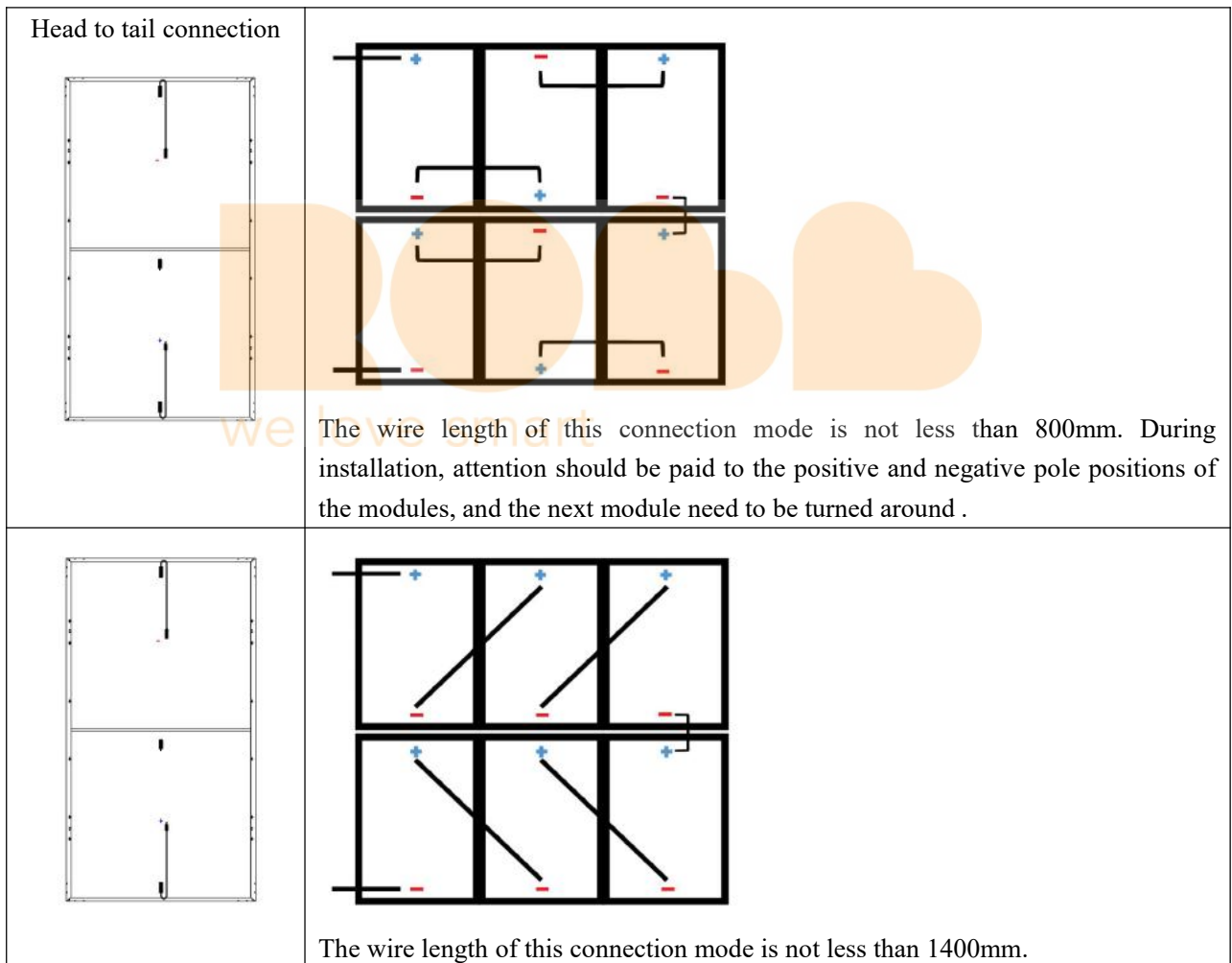

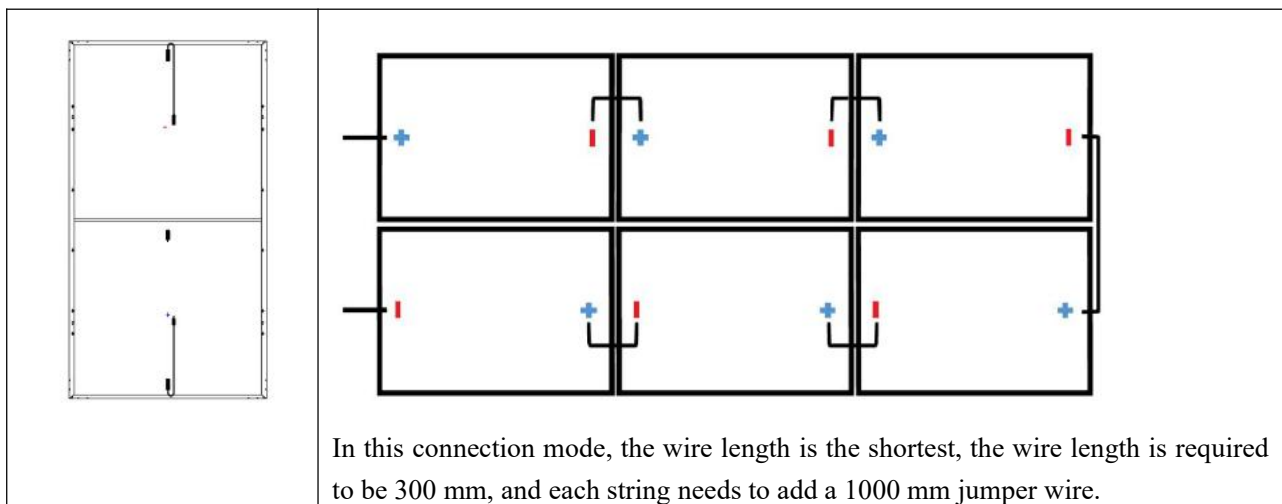

7 Electrical installation

7.1 Electrical property

7.1.1 Under normal conditions, a photovoltaic module is likely to experience conditions that produce more current and voltage than reported at standard test conditions. Accordingly, the values of ISC and VOC marked on this module should be multiplied by a factor of 1.25 when determining module voltage ratings, conductor current ratings, fuse sizes, and size of controls connected to the PV output.

7.1.2 Try to use the modules with the same configuration in the same PV system. If the modules are connected in series, the total voltage is the sum of voltages of all the modules. The maximum voltage of string does not exceed the maximum system voltage of the modules (the maximum system voltage of Bluesun solar modules is 1500V), the maximum number of modules that can be connected in a series string must be calculated in accordance with applicable regulations, make sure the open circuit voltage of string does not exceed the maximum system voltage of the modules and the other electrical DC modules required at the minimum temperature at the PV system location. Using the following formula:

$$\text{System voltage} = N * V_{oc} * [1 + \lambda_{v_{oc}} (T_{min} - 25^{\circ}\text{C})]$$

N—number of modules in series

V_{oc}—open circuit voltage at STC (refer to product label or data sheet)

λ_{v_{oc}}—Thermal coefficient of V_{oc} of each module (refer to product data sheet)

T_{min}—minimum ambient temperature at the PV system location

7.1.3 If the PV system requires the installation of high current, several PV modules can be connected in parallel, and total current is the sum of current of all the modules. The maximum parallel number of the

modules $N = I_{max} \text{ (fuse rating)} / I_{sc}$.

7.1.4 An over-current protection device with appropriately rated must be used when reverse current could exceed the value of the maximum fuse rating of the module, an over-current protection devices is required for each series string if more than two series strings are connected in parallel.

7.1.5 When installing the module, place the end with the junction box up and try to avoid the rain.

7.1.6 Do not carry out installation in rainy weather, because humidity will void the insulation protection, Thus cause safety accidents.

7.2 Cables and wiring

7.2.1 Use a junction box with a degree of protection IP67 or above. The junction box has a connected cable and connector. Each module has two single-conductor wires, one positive and one negative, which are pre-wired inside the junction box. Installers can connect two modules by firmly inserting the positive connector of a module into the negative connector of the other module. Refer to the following table for details of junction box.

7.2.2 Never perform pretreatment to modules including connector, junction box and cable with lubricating oil or cleaning agent made of alkanet materials during installation.

7.2.3 The cross section area of the cable and connector capacity selected must satisfy the maximum short-circuit current of the system (It is recommended that the cross section area of the cable used for the single module is 4mm^2 , Please note that the temperature limit range of the cable is $-40^{\circ}\text{C} \sim +90^{\circ}\text{C}$).

7.2.4 When fastening the cables to the supporting rail, pay attention to avoid mechanical damage to the cables or modules, and also making a special design to protect the cables from environmental corrosion and direct sunshine, for example, put the cable into the supporting beam or special pipes with UV-resistant materials. The cables designed are sunlight resistant and waterproof, but also to avoid direct sunlight exposure and water immersion of the cables.

7.3 Connectors

7.3.1 When connecting modules, make sure that the connectors of the same series module shall come from the same manufacturer or totally be compatible with each others, and the same requirements shall go to the connection terminals of series string and PV system, because the connectors from different manufacturers may not be compatible with each others, which easily leads to mismatch risk.

7.3.2 Ensure that connector caps are tightened before connecting the modules, keep connectors dry and clean. Do not attempt to make an electrical connection when the connectors are wet, soiled, or otherwise faulty conditions. Avoid sunlight exposure and water immersion of the connectors.

7.4 Bypass diodes

The junction box of the Bluesun module contains bypass diode and forms a parallel structure with the solar cell circuit. When the solar cell sheet is blocked or damaged, a hot spot phenomenon occurs locally in the module, and the diode will operate so that the current is no longer discharged from the hot spot solar cell flow, thereby limiting module heat and performance loss. Please note that bypass diodes are not overcurrent protection devices.

7.5 Grounding

7.5.1 Modules use anodized aluminum alloy frame as a rigid support, in order to avoid modules by lightning and electrostatic damage, as well as the protection of personal safety, all module frames and mounting racks must be grounded. If there is no special provision, please follow the International Electrotechnical Commission standards or other international standards. Use the recommended connection terminals to connect the grounding cable to the module frame. Use 12 AWG copper wire for the grounding wire. As shown in Figure 5 on the module ground hole and its label, Figure 6 shows the module grounding method.



Figure 5 Grounding hole and ground label

Figure 6 Grounding method

7.5.2 The frames have pre-drilled grounding holes and brand with signs, these holes should be only used for grounding purposes, but not for mounting the modules. And do not drill any additional grounding holes on the frames of the module, which may void the warranty.

7.5.3 For optimum power output, it is recommended to ground the DC negative pole of the module array.

7.5.4 The grounding cables must be fully contact with inside of the aluminum alloy, and the connection terminal must penetrate the oxidation coating of frame during grounding. Connecting the module frames and supporting beams using suitable grounding conductors can achieve good grounding. If the supporting system is made of metal, the surface must be electroplated and have excellent conductivity.

7.5.5 The grounding cables must be connected to the earth through a suitable grounding electrode. Recommend to use the grounding accessories (lugs) to connect the cables. Welding grounding cable to the jack of lugs, then inserting M4 screws into the ring of the lugs and the grounding holes of module frames, fastening with M4 nuts. Spring washers should be used to prevent the screws from loosening and lead to poor grounding.

7.5.6 If the module is used in high-temperature and high-humidity environment, Bluesun solar suggest the customer configure the inverter which allows negative grounding and contains isolation transformer (as shown in figure 7).

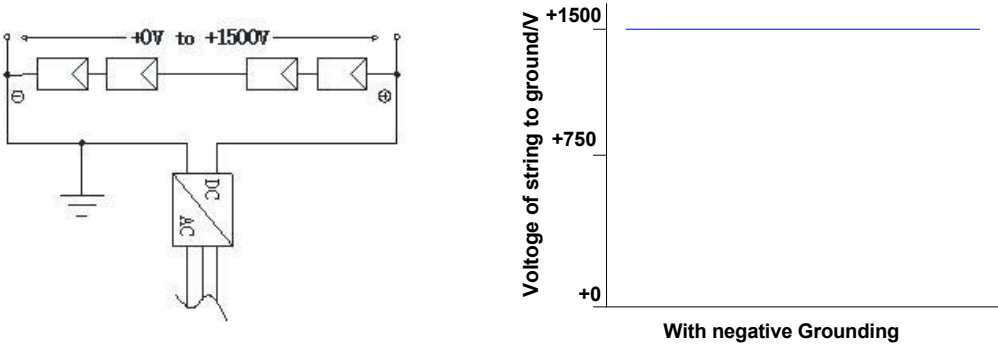

Figure 7 Schematic diagram for grounding potential of the inverter

7.5.7 Bluesun modules may be grounded using a third-party earthing device, provided that the earthing must be reliable. The earthing device is operated in accordance with the manufacturer's requirements.

8 Maintenance and care

Modules need to be inspected and maintained regularly, especially during the warranty period. To ensure optimum performance of the modules, the following maintenance measures are recommended.

8.1 Cleaning

When modules are working, there should not be environmental influence factors to cover shadows in the modules, such as other modules, supporting rail, plants, large number of dust etc., which may directly reduce the power output and may even cause regional hot-spot effect. Therefore clean the glass surface on a regular basis, clean modules take measures so as:

- a) The frequency of the cleaning module depends on the rate of dirt buildup. Under normal conditions, the rain will clean the surface of the module, but it is still need to regularly use a soft sponge or cloth (dry or wet) cleaning modules. Any situation cannot use of rough surface materials to clean modules, no use of acid and alkali cleaner to remove dirt.
- b) Avoid pressing part of the module hard during cleaning, which may cause glass deformation, cell damage and reduction of the module’s life.
- c) Remove the snow covered on the module in time to avoid the module damage caused by long-term accumulation of snow cover and freezing of melted snow.
- d) when cleaning the negtive of the module needs to avoid piercing negtive-sheet.
- e) It is recommended that modules be cleaned in the early morning or late afternoon when light is low and the module temperature is low, especially for areas with high temperatures.

f) Do not attempt to clean modules that are damaged by glass or have exposed electrical wiring, which may be subject to an electric shock hazard.

8.2 Visual inspection

Please carefully check the modules of the existence of visual defects, focusing on the following items:

- a) Check whether the module glass is broken.
- b) Check if the front of the module is obstructed by obstacles or foreign objects.
- c) Check the module negative-sheet whether there is hot, negative film raised, burn through the traces and so on.
- d) Check whether the cell bus-bar is corroded, whether encapsulation materials of the module has delamination, bubbles, etc.
- e) Check the tightness of the bolts and the electrical connections at the connection points between the modules and the supporting rail.

8.3 Inspection of connector and cable

8.3.1 It is advisable to carry out a preventive check every 6 months and check the following:

- a) Check Junction box adhesive for cracks or cracks.
- b) Check the connector interface sealing and whether there is loose, melt deformation, aging or corrode.
- c) Check that the cable connections are secure and that the modules are properly grounded.

8.3.2 When module is found to be defective, consult a qualified service technician. If servicing is required, it should be serviced by a qualified service technician. Module exposure generates high voltages in the sun, so cover the modules with opaque material when servicing modules to prevent electrical shock.

Note:

1. if found in the maintenance of any problems, feed negative to the professional service personnel for confirmation;
2. If using maintenance and repair measures not included in this manual, consult your local dealer for professional support.

9 Disclaimer of liability

9.1 Because the use of the manual and the conditions or methods of installation, operation, use and maintenance of photovoltaic (PV) product are beyond Bluesun's control, Bluesun does not accept responsibility and expressly disclaims liability for loss, damage, or expense arising out of or in any way connected with such installation, operation, use or maintenance.

9.2 Bluesun shall not be liable for damage to the product resulting from the installation or the design of the power generation system.

9.3 No responsibility is assumed by Bluesun for any infringement of patents or other rights of third parties, which may result from use of the PV product, No license is granted by implication or otherwise under any patent or patent rights.

9.4 In the installation of modules, the customer is not in accordance with the requirements of the listed this manual operation, Bluesun does not provide any warranty.

9.5 The information in this manual is based on Bluesun's knowledge and experience and is believed to be reliable, but such information including product specification (without limitations) and suggestions do not constitute a warranty, expresses or implied.

9.6 Bluesun reserve the right to change the manual, module technical specification, nameplate or product information sheets without prior notice.

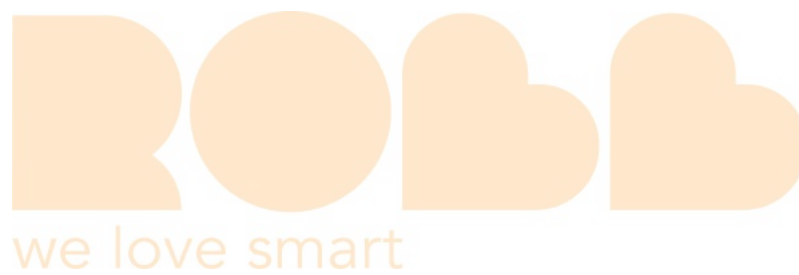

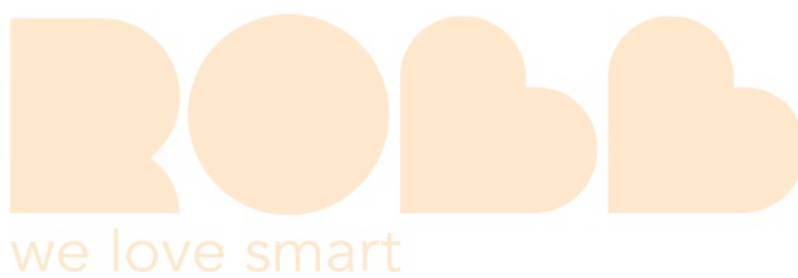

Bluesun Solar Co., Ltd
Add: 1499 Zhenxing Road, Shushan District, 230031 Hefei, China
Tel: +86 (158) 5821 3997
Fax: +86 (551) 6565 2651
Email: info@bluesunpv.com
Service: Service@bluesunpv.com